

---

# AQUA<sub>2</sub>elite

---

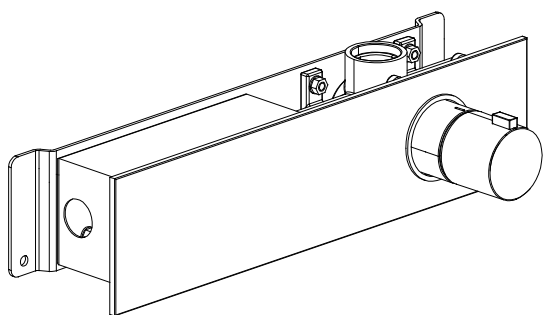

---

---

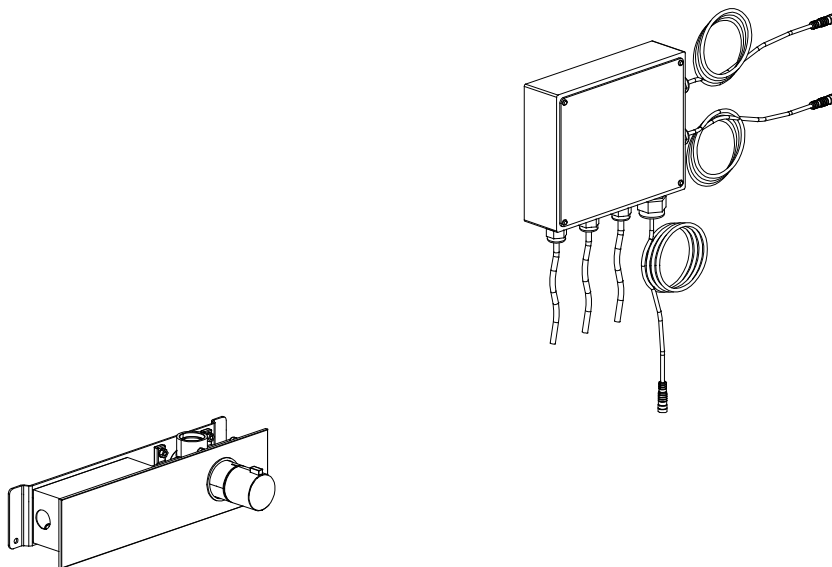

Utensili necessari / Tools needed / Outils nécessaires

Ø 10 mm.

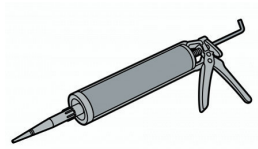

2.5 mm.

Indossare guanti di protezione

Wear protective gloves

Utiliser des gants isolants de protection

# ITA

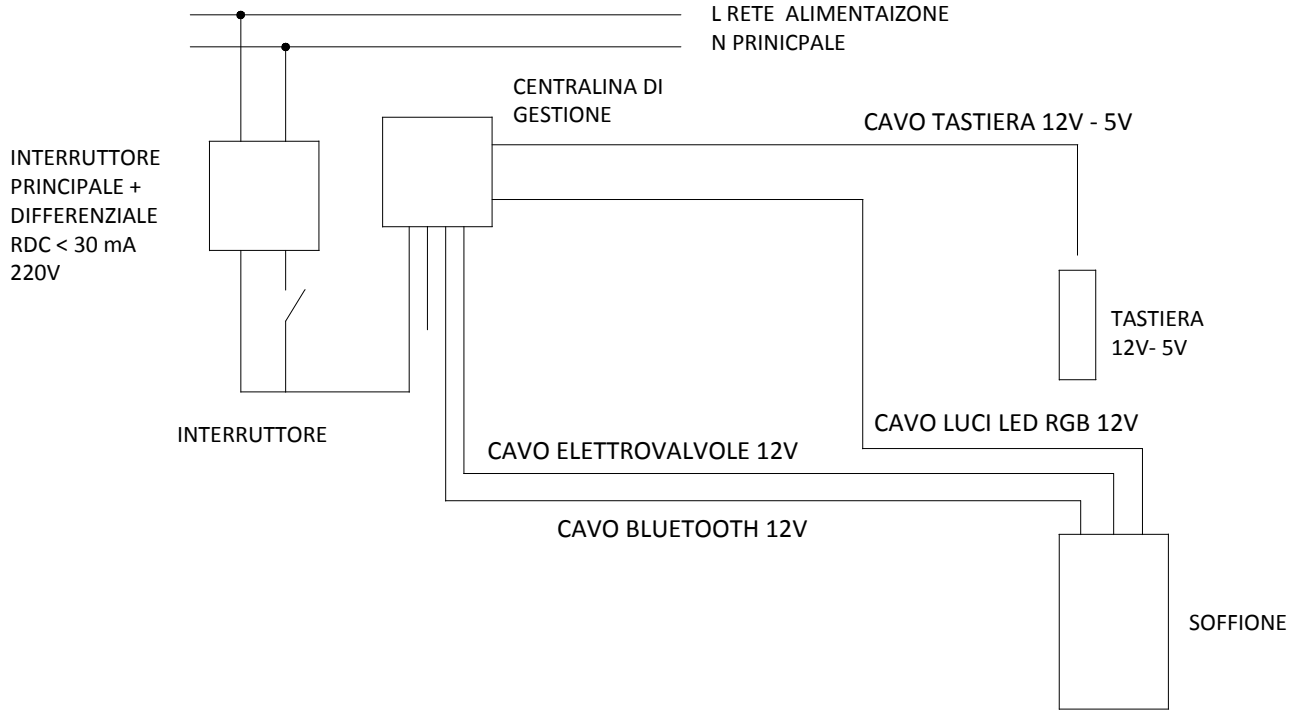

# EN-FRA

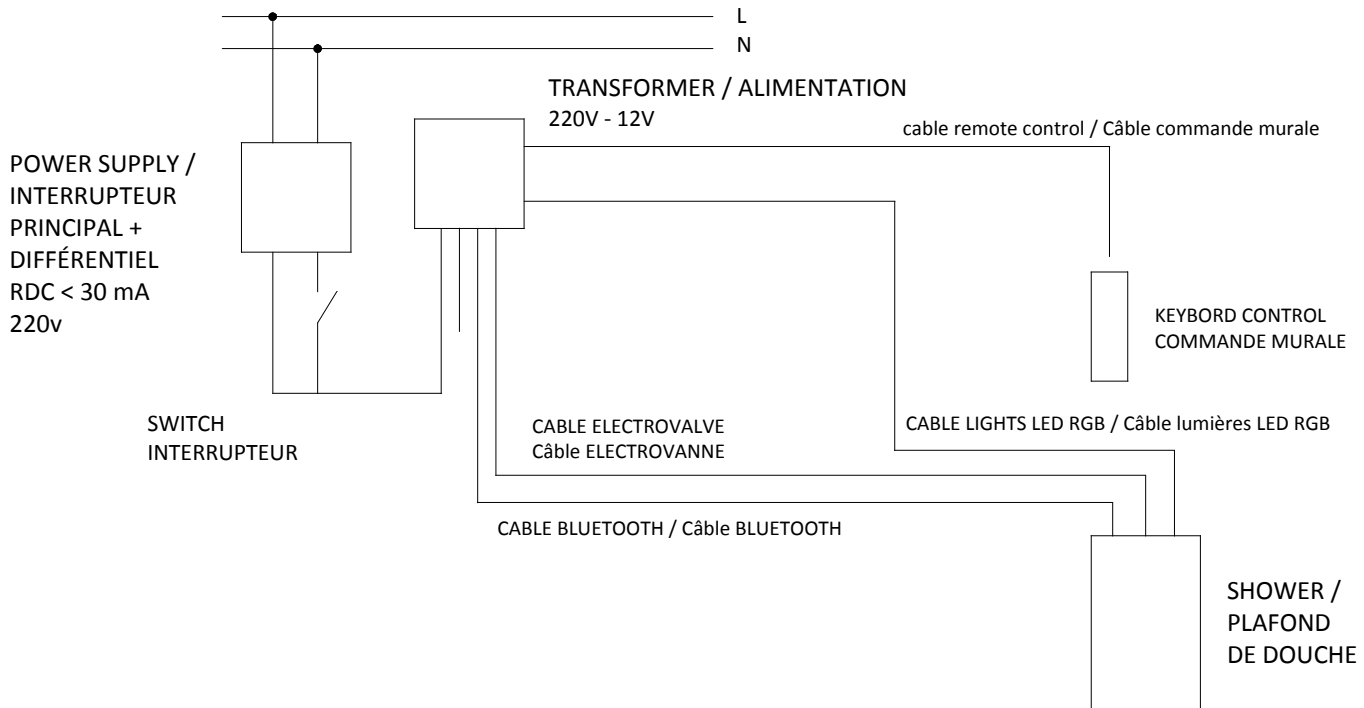

## Collegamento elettrico / Electrical connection / Branchement électrique

CAVO LED / LED CABLE / CÂBLE LED  
12 Vac (5 Mt.) ø min. 20 mm

CAVO ELETTROVALVOLE/ELECTROVALVE CABLE/CÂBLE ELECTROVANNE  
12 Vac (5 Mt.) ø min. 20 mm

CAVO BLUETOOTH/BLUETOOTH CABLE/CÂBLE BLUETOOTH  
12 Vac (5 Mt.) ø min. 20 mm

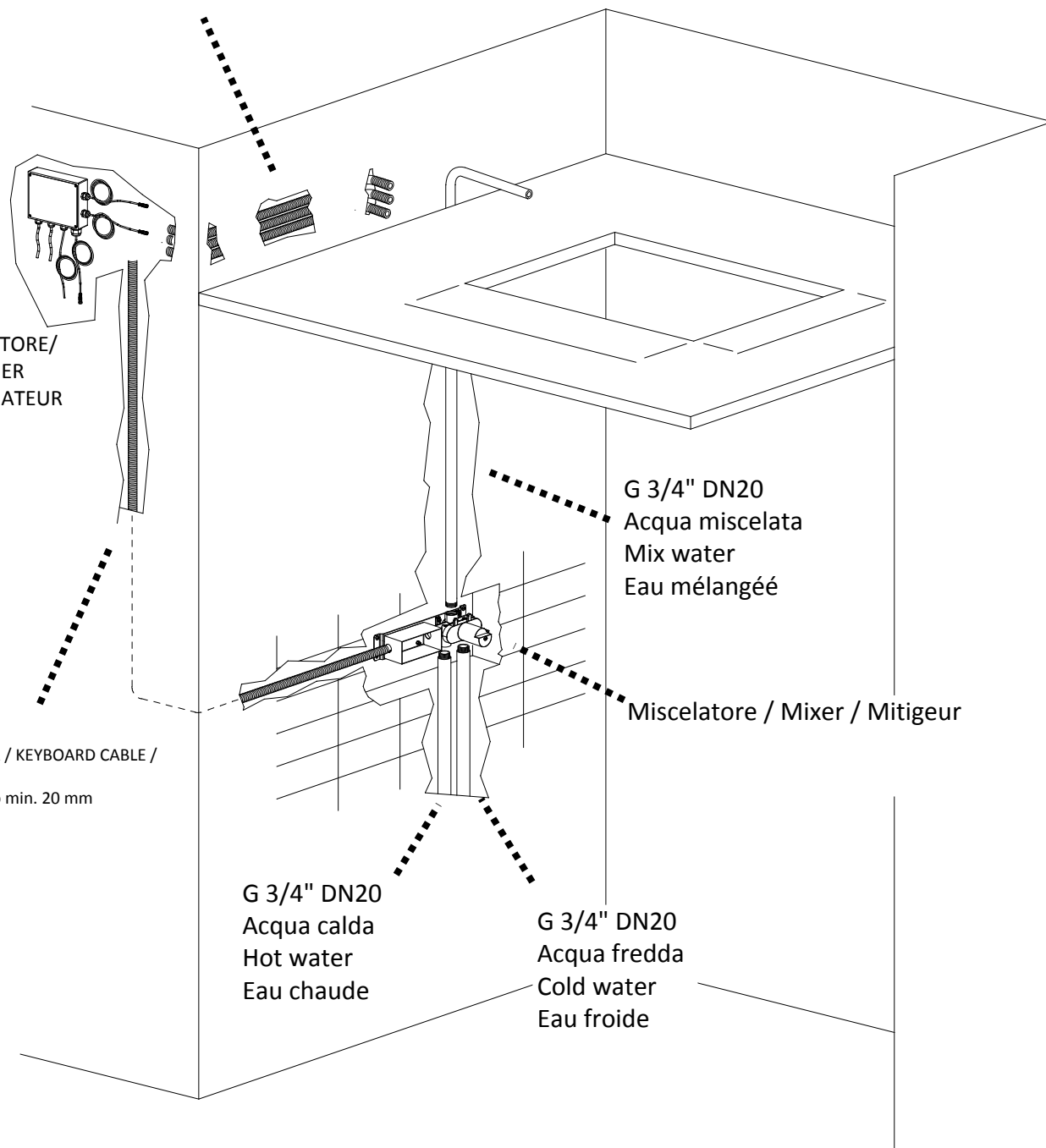

**E' necessaria l'installazione di un alimentatore ON/OFF sull'alimentazione del trasformatore**  
**Require installation of controll key for switch ON/OFF lights on trasformer power supply**  
**Il est nécessaire d'installer un interrupteur marche/arrêt (non fourni d'usine) sur l'alimentation du transformateur (fourni d'usine)**

# Installazione / Installations / Installation

CAVO TASTIERA / KEYBOARD CABLE / CÂBLE CLAVIER  
12 Vac (3 Mt.) ø min. 20 mm

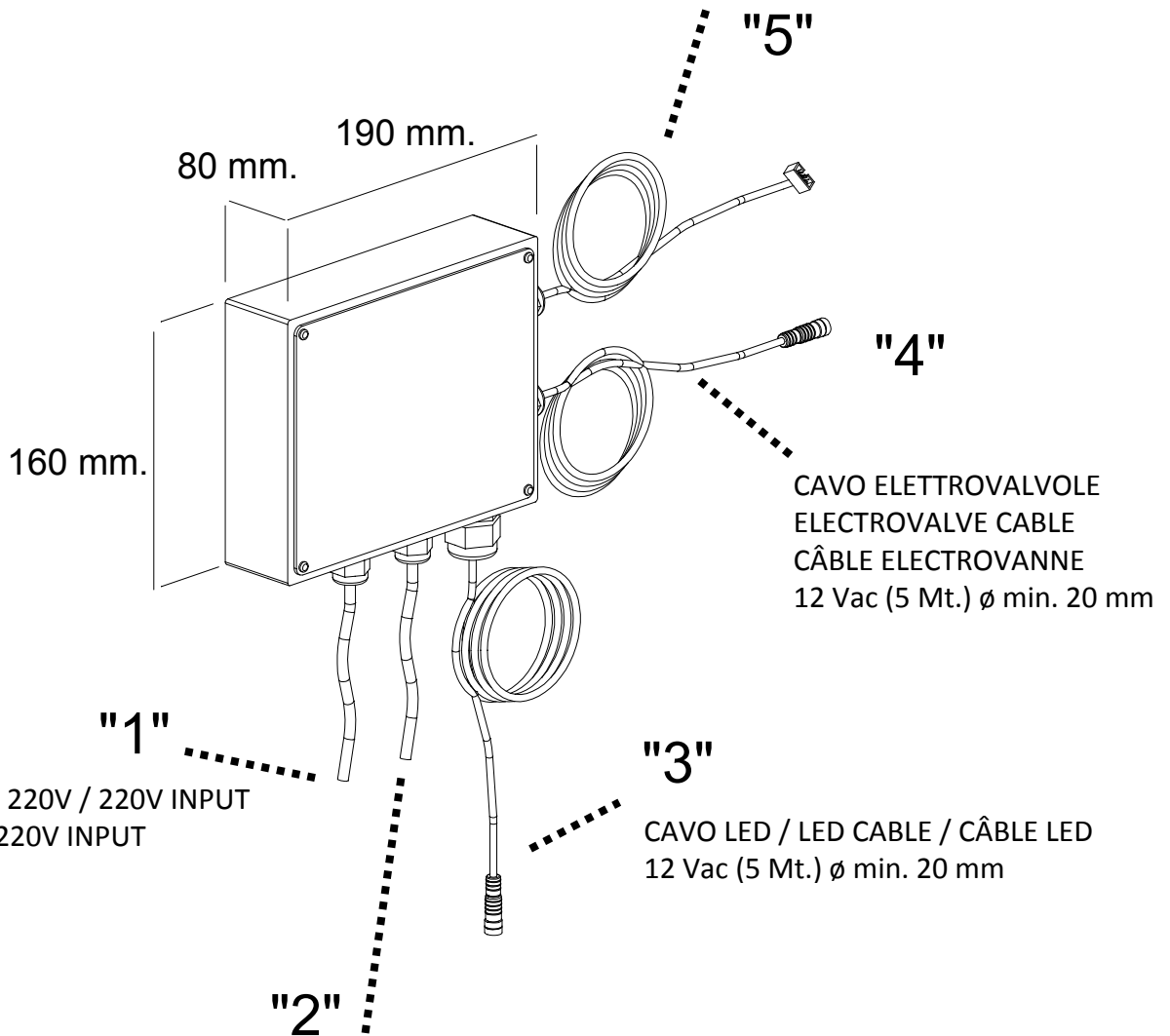

CAVO ENTRATA 220V / 220V INPUT  
CABLE / CÂBLE 220V INPUT  
30 CM.

CAVO ELETTROVALVOLE  
ELECTROVALVE CABLE  
CÂBLE ELECTROVANNE  
12 Vac (5 Mt.) ø min. 20 mm

CAVO BLUETOOTH / BLUETOOTH CABLE / CÂBLE BLUETOOTH  
12 Vac (5 Mt.) ø min. 16 mm

# Installazione / Installations / Installation

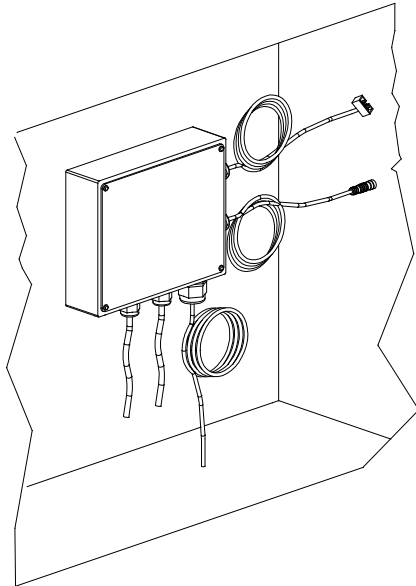

Inserire i cavi nella direzione corretta :

cavo "5" tastiera = collegamento tastiera  
cavo "4" elettrovalvole = collegamento elettrovalvole soffione  
cavo "3" led = collegamento led soffione  
cavo "2" Bluetooth = collegamento Bluetooth soffione  
cavo "1" input 220V = collegamento a rete elettrica

Insert the cables in the correct direction:

cabl "5" keyboard = keyboard connection  
cabl "4" solenoid valve = valve overhead valve connection  
cabl "3" led = headlight led connection  
cabl "2" Bluetooth = Bluetooth headset connection  
cabl "1" input 220V = mains connection

Insérer les câbles dans la bonne direction :

câble "5" clavier = branchement clavier  
câble "4" électrovannes = branchement électrovannes au plafond de douche  
câble "3" LED = branchement LED au plafond de douche  
câble "2" Bluetooth = branchement Bluetooth au plafond de douche  
câble "1" INPUT 220V = branchement au réseau électrique

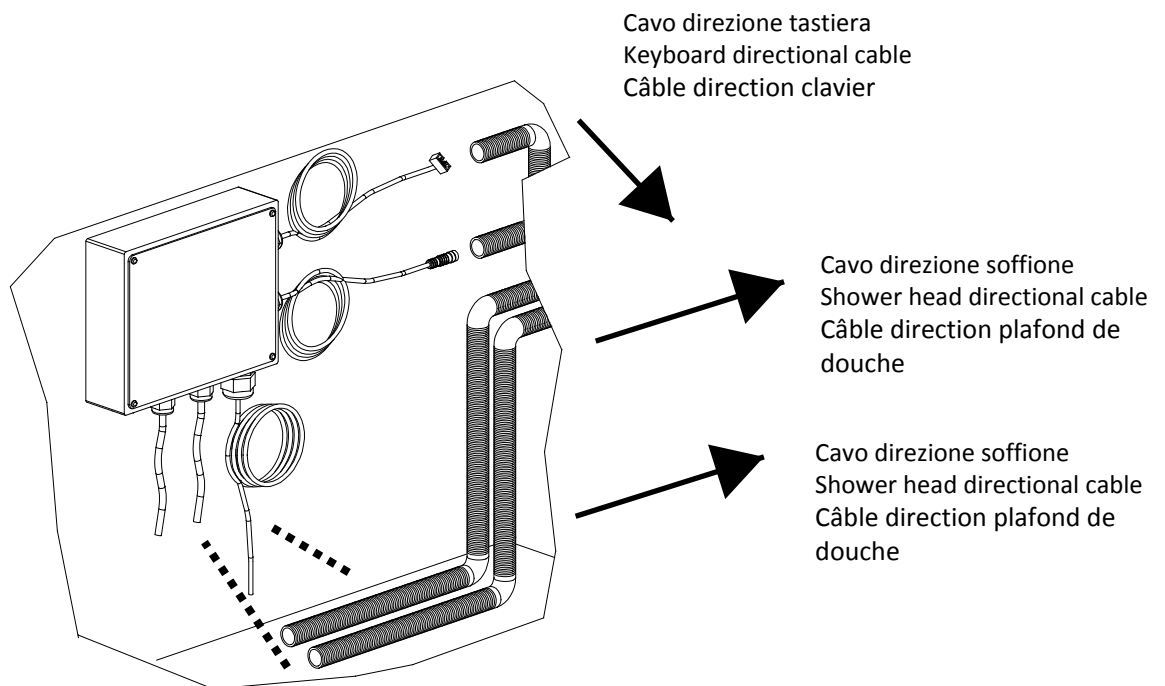

Cavo direzione tastiera  
Keyboard directional cable  
Câble direction clavier

Cavo direzione soffione  
Shower head directional cable  
Câble direction plafond de  
douche

Cavo direzione soffione  
Shower head directional cable  
Câble direction plafond de  
douche

# Installazione / Installations / Installation

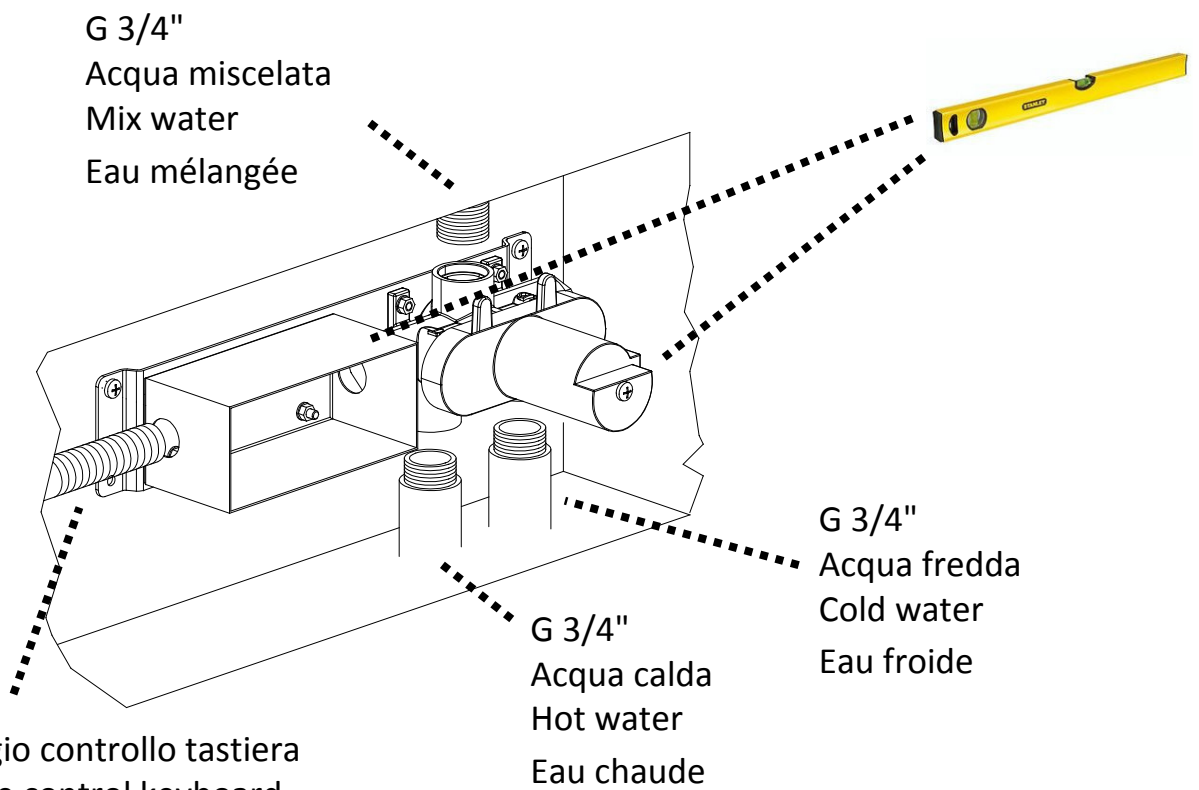
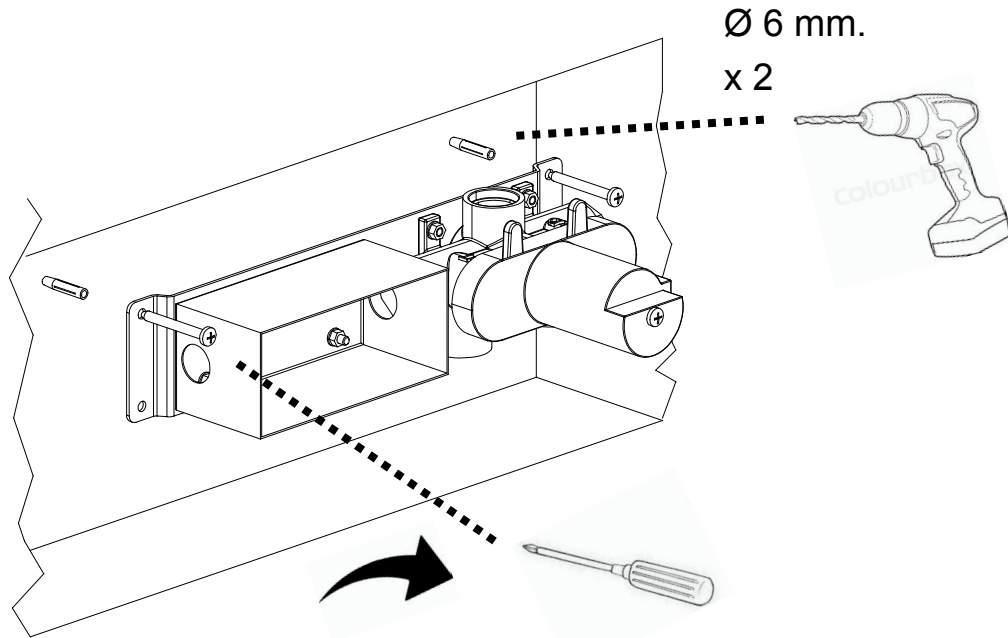

Cavo passaggio controllo tastiera  
Cable passage control keyboard  
Câble passage contrôle du clavier

## Installazione / Installations / Installation

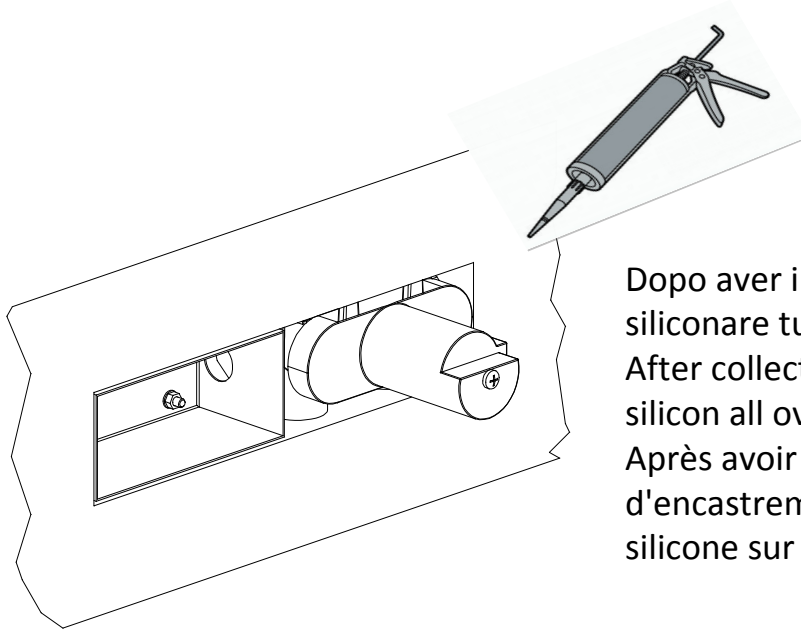

Dopo aver incassato il corpo incasso  
siliconare tutto il bordo  
After collecting the recessed body  
silicon all over the board  
Après avoir installé le corps  
d'encastrement, il faut mettre le  
silicone sur tout le bord du produit

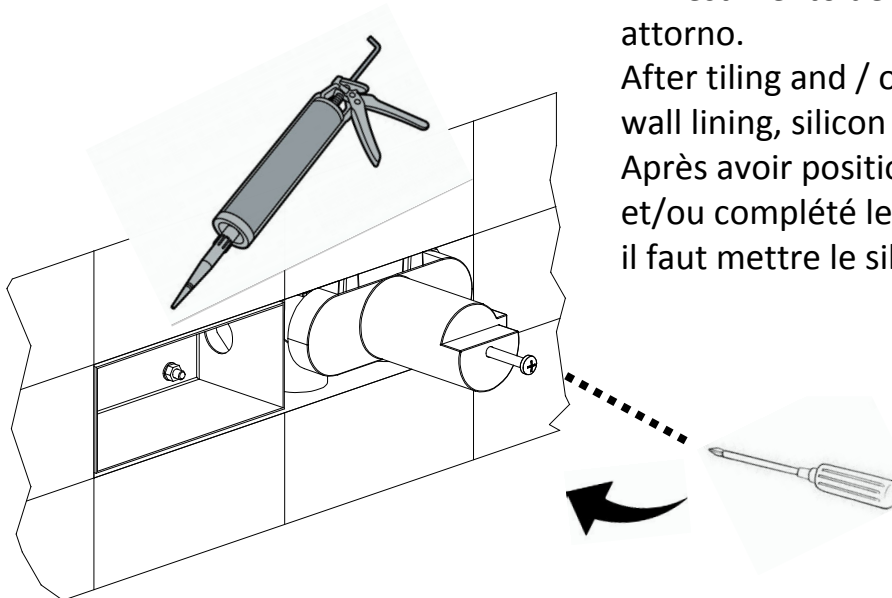

Dopo aver piastrellato e/o completato  
il rivestimento della parete, siliconare  
attorno.  
After tiling and / or completing the  
wall lining, silicon around.  
Après avoir positionné les carrelages  
et/ou complété le revêtement mural,  
il faut mettre le silicone tout atour.



# Installazione / Installations / Installation

Togliere la protezione del  
miscelatore

Remove the mixer cap

Lever la protection du mitigeur

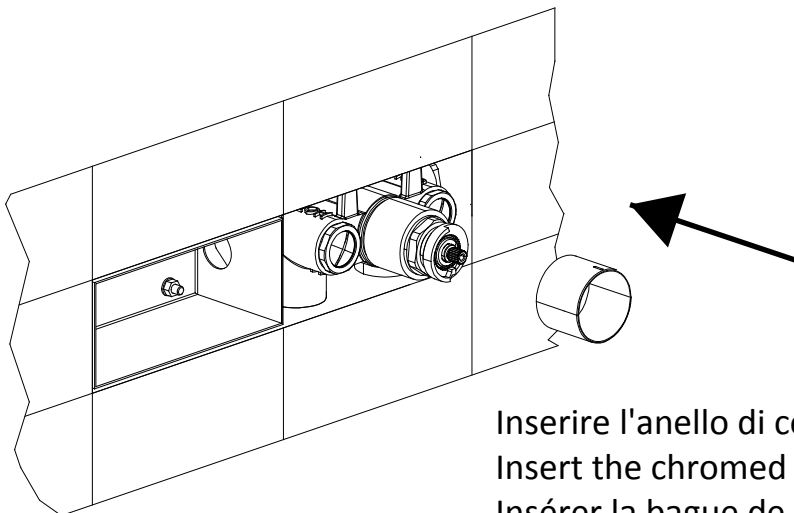
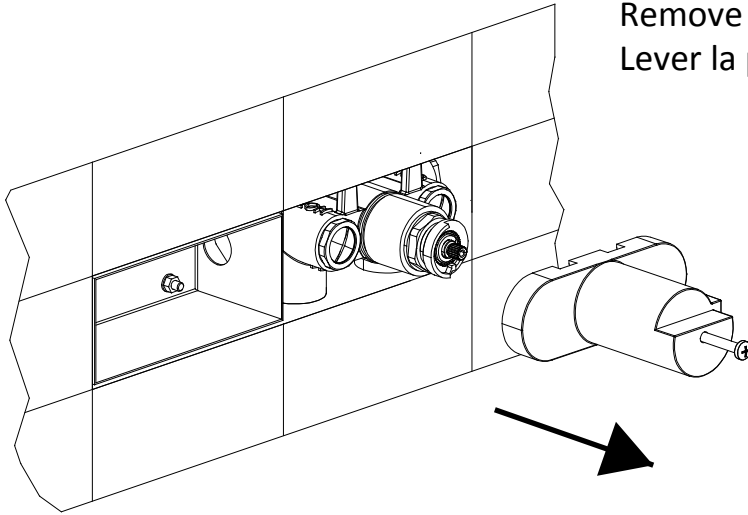

Inserire l'anello di copertura cromato

Insert the chromed cover ring

Insérer la bague de couverture chromée

# Installazione / Installations / Installation

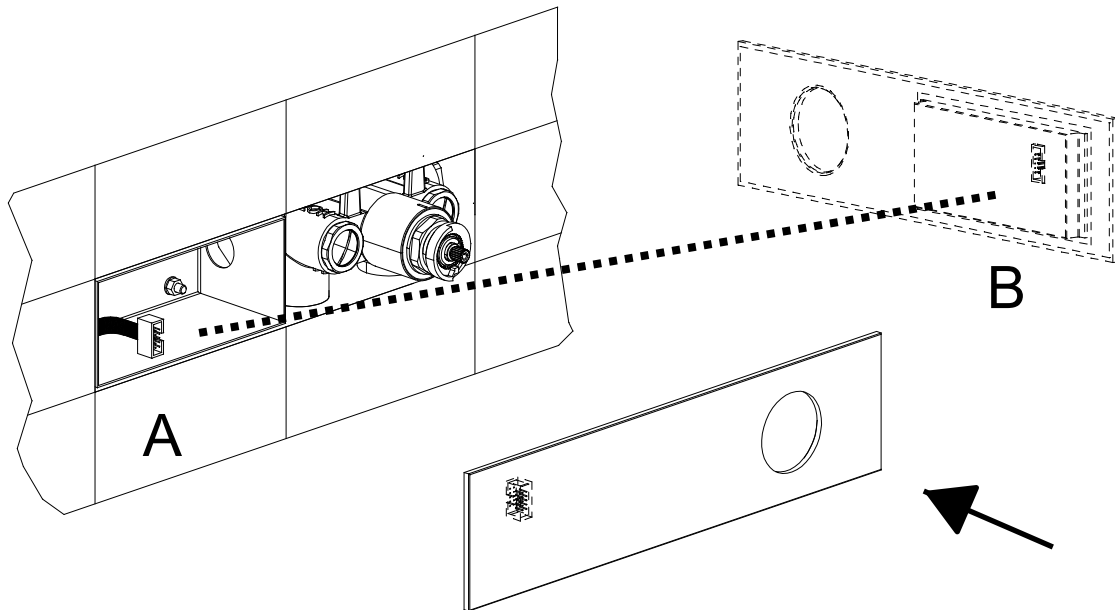

Collegare il cavo della tastiera "A" proveniente dalla centralina al connettore posto sul retro del piastra in vetro "B"  
Connect the keyboard cable "A" from the control unit to the connector located on the back of the "B" glass plate  
Brancher le câble du clavier "A", provenant de l'unité de gestion électrique, au connecteur positionné à l'arrière de la plaque en verre "B"

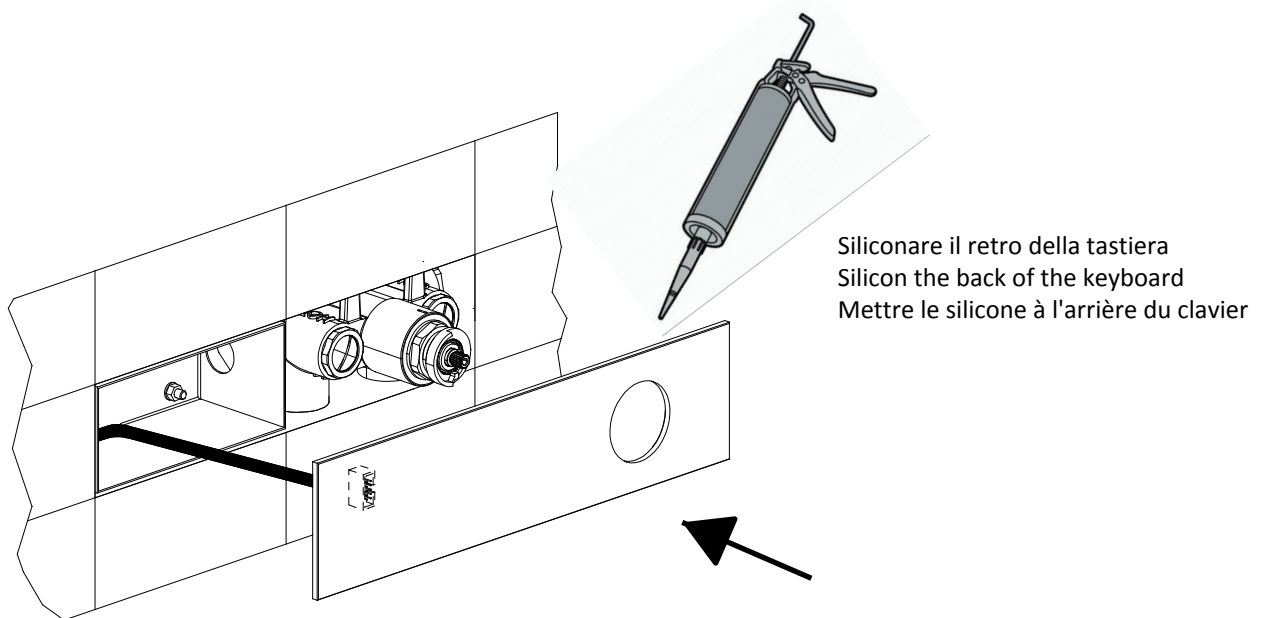

Una volta collegato il cavo, inserire la tastiera  
Once the cable is connected, insert the keyboard  
Une fois que le câble a été branché, insérer le clavier

# Installazione / Installations / Installation

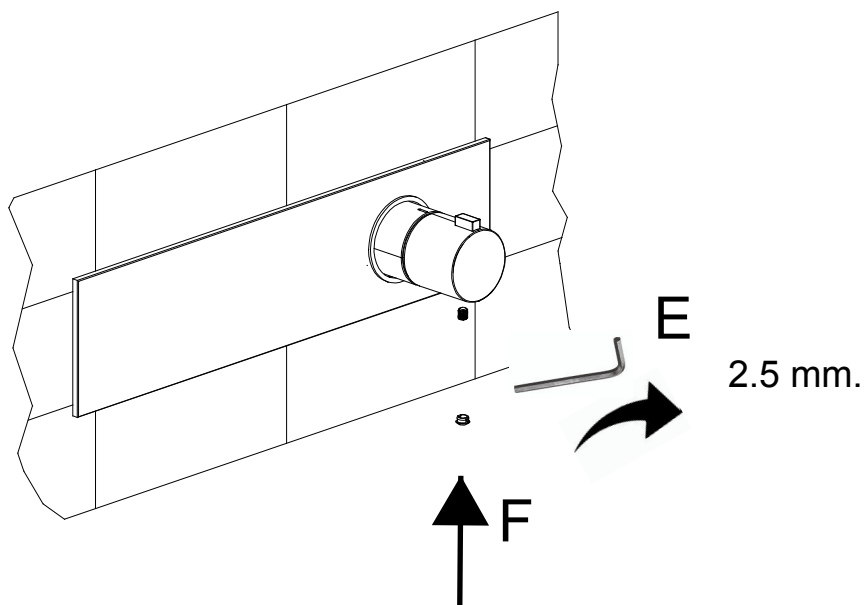
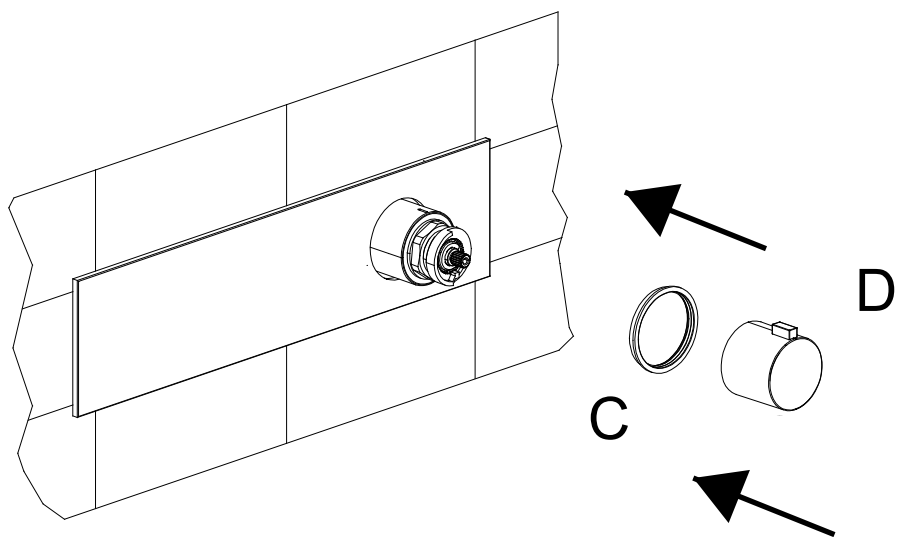

# Installazione / Installations / Installation

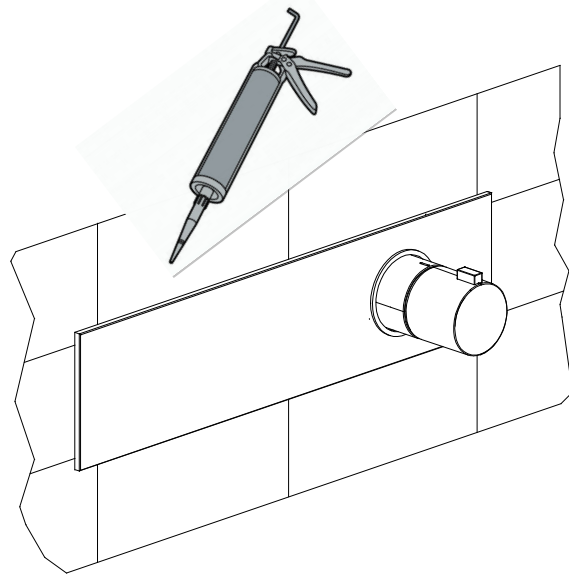

Siliconare tra tastiera e rivestimento in modo da non far infiltrazioni d'acqua e causare mal funzionamento della tastiera





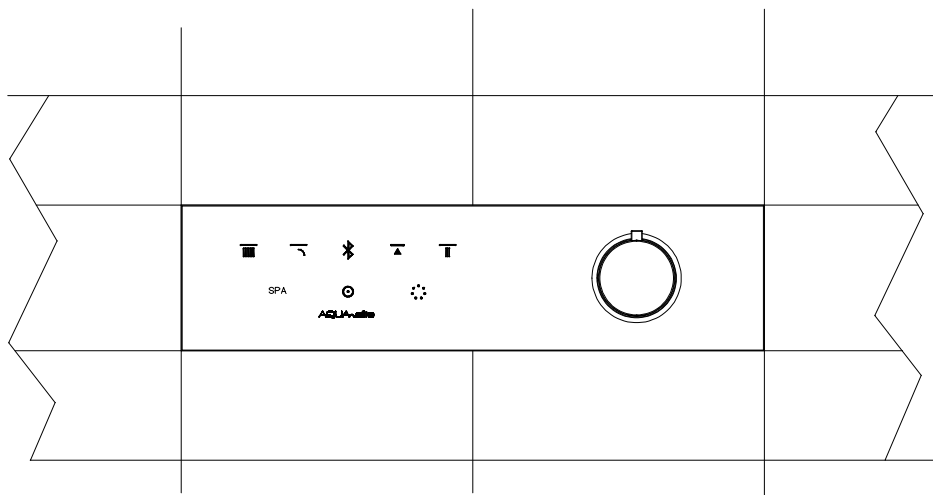

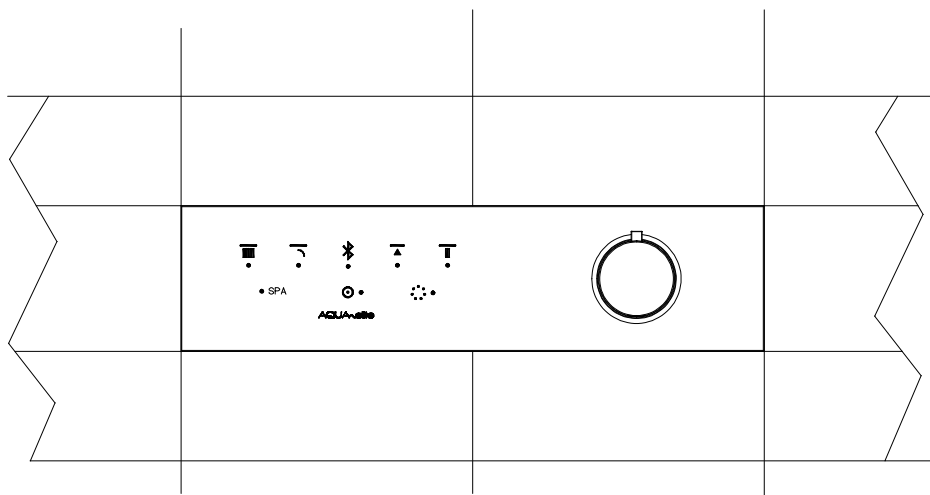

Silicon between the keyboard and the lining so as not to infiltrate water and cause malfunction of the keyboard

Mettre le silicone entre le clavier et le revêtement mural pour éviter des infiltrations d'eau et causer un mauvais fonctionnement du clavier.



# Funzioni / Functions / Fonctions



-  Getto Pioggia / Rain jet / Jet pluie
-  Getto Cascata / Cascade jet / Jet cascade
-  Getto nebulizzato / Mist jet / Jet brumisation
-  Getto Colonna / Colum jet / Jet colonne d'eau
-  Bluetooth / Bluetooth / Bluetooth
-  Programmi SPA / SPA program / Programmes séquentiels SPA
-  Selezioni colori e ciclo automatico / Color selections and automatic loop / Sélections couleurs et cycle automatique
-  Attivazione tastiera e off / Keyboard activation and off / Activation du clavier et arrêt

# Funzioni / Functions / Fonctions

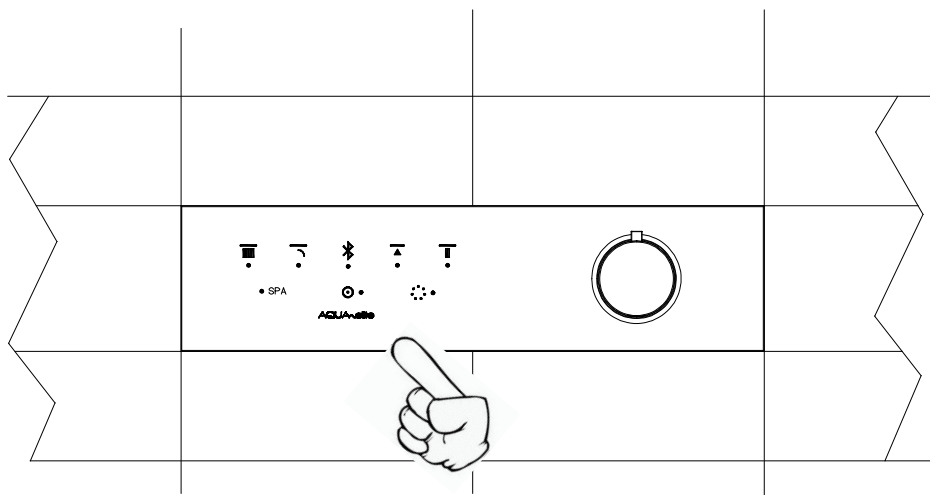

- Per attivare la tastiera tenere premuto per 3 secondi / Premere 1 volta per spegnere
- To activate the keyboard hold down for 3 seconds / Press 1 time to turn off
  - Pour activer le clavier, maintenez enfoncé pendant 3 secondes / Appuyez 1 fois pour éteindre

Programmi SPA :

n° 4 programmi differenti, in termini di tempo, getti e luci.  
Premere il led SPA per scegliere il programma.

SPA programs :

n° 4 different programs, in term of time, jets and lights.  
Press the SPA LED to select the program.

Programmes séquentiels SPA :

n° 4 programmes différents, en terme de temps, jgestion jet d'eau et lumières.  
Appuyer sur le symbol SPA et sélectionner le programme.

**ATTENZIONE!! : PREMERE IN CORRISPONDENZA DEL LED ACCANTO ALLA FUNZIONE CHE SI VUOLE ATTIVARE, NON SULL'ICONA**

**CAUTION!! : PRESS ON LED ON THE FUNCTION THAT WILL BE ACTIVATED, NOT ON THE ICON**

**ATTENTION !! APPUYER SUR LE BOUTON ROND (LED COULEUR BLEU) POSITIONNÉ PRÈS DE LA FONCTION QU'ON VEUT DÉCLENCHER ET NON SUR LE SYMBOLE SÉRIGRAPHIE SUR LA PLAQUE EN VERRE**

## Dichiarazione di conformità / Declaration of conformity

### CARATTERISTICHE TECNICHE

Tensione di alimentazione 220Vac +/- 3%  
Assorbimento massimo: 300 mA  
Servizio di funzionamento: Continuo  
Temperatura ambiente di funzionamento: da 0 a +40°C  
Umidità relativa senza condensa: 5% a 90%  
Grado di protezione: IP55  
Connessioni d'ingresso e d'uscita: Morsetto a carrello  
Norma di sicurezza: Non richiesta  
Norma ENIC: EN55022/B  
Prodotto LASER di Classe 2  
Le radiazioni luminose di questa classe sono considerate a basso rischio, ma potenzialmente pericolose. Normalmente non producono danni permanenti se viste per pochi istanti da un occhio non protetto.

### AVVERTENZE

Prima di collegare l'unità per la prima volta, leggere attentamente le sezioni seguenti. Le tensioni alternate delle reti elettriche variano a seconda del paese.  
Assicurarsi che la tensione alternata presente nella vostra zona sia conforme con la tensione richiesta.  
NON E' CONSENTITO L'UTILIZZO DI UNA CENTRALI DI GESTIONE DIVERSA DA QUELLA FORNITA DA ANPA.  
PRIMA DI QUALUNQUE INTERVENTO TECNICO SULLA CENTRALE DI GESTIONE DEVE ESSERE AUTORIZZATO DA UN TECNICO ANPA.  
IN CASO DI NON RISPETTO DI QUANTO SOPRA DESCRITTO LA GARANZIA NON AVRA' PIU' VALORE.

### TECHNICAL FEATURES

Voltage supply: 220Vac +/- 3%  
Maximum consumption: 300 mA  
Functioning: Continuous  
Ambient operating temperature: 0-+40 °  
Relative non-condensing humidity: 5% -90%  
Protection degree: IP55  
Input and output connection: Rising clamp terminal block  
Safety standard: Not required  
Enic standard: EN55022/b  
Class 2 LASER product  
Class 2 light radiations are considered as posing a low risk, but potentially dangerous.

### WARNING

Before connecting the unit for the first time, please read carefully the following sections.  
AC voltages varies according to each country.  
Ensure that the voltage of your local power supply corresponds to the required voltage.

### CARACTÉRISTIQUES TECHNIQUES

Tension d'alimentation : 220Vac +/- 3%  
Adsorption maximale : 300 mA  
Service de fonctionnement : continu  
Température ambiante de fonctionnement : de 0 à +40°  
Humidité relative sans condensation : de 5% à 90%  
Degrée de protection : IP55  
Connexions d'entrée et de sortie : bornes à bogies  
Normes de sécurité : non demandée  
Norme ENIC : EN55022/B  
Produit LASER Classe II  
Les radiations lumineuses de cette Classe sont considérées à bas risque, mais dangereuses potentiellement.  
Normalement ne produisent pas des dégâts permanents si vu pour quelque instant d'un oeil sans protection

### AVERTISSEMENTS

Avant de brancher l'unité la première fois, veuillez lire attentivement les sections suivantes.  
Les voltages des réseaux électriques varient à second du pays.  
S'assurer que le voltage dans votre zone soit conforme avec le voltage prévu et déclaré par l'usine.

## Dichiarazione di conformità / Declaration of conformity / Déclaration de conformité

### CARATTERISTICHE TECNICHE

Tensione di alimentazione 12Vcc +/- 3%  
Assorbimento massimo: 1.3 A – 8.4 A  
Servizio di funzionamento: Continuo  
Temperatura ambiente di funzionamento: da 0 a +40°C  
Umidità relativa senza condensa: 5% a 90%  
Grado di protezione: IP55  
Conessioni d'ingresso e d'uscita: Morsetto a carrello  
Norma di sicurezza: Non richiesta  
Norma ENIC: EN55022/B  
Prodotto LASER di Classe 2  
Le radiazioni luminose di questa classe sono considerate a basso rischio, ma potenzialmente pericolose. Normalmente non producono danni permanenti se viste per pochi istanti da un occhio non protetto.

### AVVERTENZE

Prima di collegare l'unità per la prima volta, leggere attentamente le sezioni seguenti. I voltaggi CA delle reti elettriche variano a seconda del paese. Assicurarsi che il voltaggio presente nella vostra zona sia conforme con il voltaggio richiesto.

### ALIMENTATORE

Tensione di alimentazione: ingresso 190 -230 VAC 50/60Hz +/- 20% uscita - 12Vcc +/- 3%  
Potenza: 48 Watt  
Si consiglia vivamente di utilizzare l'alimentatore fornito da Anpa; In caso di utilizzo di alimentatore diverso assicurarsi che le caratteristiche richieste siano compatibili con l'apparecchio.  
L'utilizzo di alimentatori con caratteristiche diverse o incompatibili possono danneggiare irreparabilmente il prodotto e far decadere la garanzia.

### TECHNICAL FEATURES

Voltage supply: 12 Vcc +/- 3%  
Maximum consumption: 1.3 A – 8.4 A  
Functioning: Continuous  
Ambient operating temperature: 0- +40 °  
Relative non-condensing humidity: 5% -90%  
Protection degree: IP55  
Input and output connection: Rising clamp terminal block  
Safety standard: Not required  
Enic standard: EN55022/b  
Class 2 LASER product  
Class 2 light radiations are considered as posing a low risk, but potentially dangerous.

### WARNING

Before connecting the unit for the first time, please read carefully the following sections.  
AC voltages varies according to each country.  
Ensure that the voltage of your local power supply corresponds to the required voltage.

### FEEDER

Voltage supply: Input 190 -230 VAC 50/60Hz +/- 20% output - 12Vcc +/- 3%  
Power: 48 Watt  
It is strongly recommended to use the feeder provided by anpa.  
If a different feeder is to be used, please ensure that is compatible with the device.  
The use of feeders with different characteristics or incompatible may damage the product and invalidate the warranty.

### CARACTÉRISTIQUES TECHNIQUES

Tension d'alimentation : 12Vcc +/- 3%  
Adsorption maximale : 1.3 A - 8.4 A  
Service de fonctionnement : continu  
Température ambiante de fonctionnement : de 0 à +40°  
Humidité relative sans condensation : de 5% à 90%  
Degré de protection : IP55  
Connexions d'entrée et de sortie : bornes à bogies  
Normes de sécurité : non demandée  
Norme ENIC : EN55022/B  
Produit LASER Classe II  
Les radiations lumineuses de cette Classe sont considérées à bas risque, mais dangereuses potentiellement.  
Normalement ne produisent pas des dégâts permanents si vu pour quelque instant d'un oeil sans protection

### AVERTISSEMENTS

Avant de brancher l'unité la première fois, veuillez lire attentivement les sections suivantes.  
Les voltages des réseaux électriques varient à second du pays.  
S'assurer que le voltage dans votre zone soit conforme avec le voltage prévu et déclaré par l'usine.

### ALIMENTATEUR

Tension d'alimentation : entrée 190 - 230 VAC 50/60Hz +/- 20% sortie - 12Vcc +/- 3%  
Puissance : 48W  
Il est fortement recommandé d'utiliser l'alimentateur fourni avec le produit.  
En cas d'utilise d'un alimentateur différent, s'assurer que les caractéristiques demandées soient compatibles avec l'appareil.  
L'utilise d'alimentateurs avec caractéristiques différentes ou incompatibles puissent endommager le produit irrémédiablement et faire invalider la garantie.



---

---

---

---

---

---

---

---

---

---

---

---

---

---

AQUAelite / ANPA s.r.l.

Viale dello sport, 16/18 2106 Gavirate VA Italy

T.+39 0332 732906 | F. +39 0332 735819 | [www.aquaelite.it](http://www.aquaelite.it) | [info@aquaelite.it](mailto:info@aquaelite.it)

---

---



E

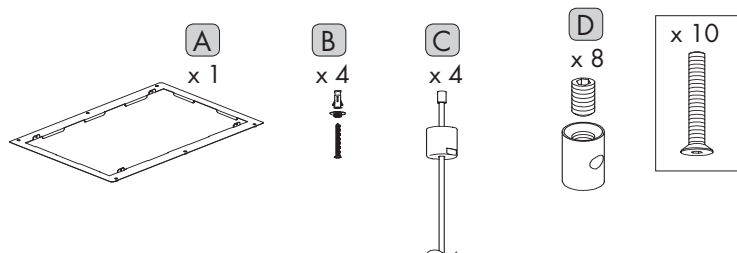

Utensili necessari / Tools needed

Indossare guanti di protezione  
Wear protective gloves

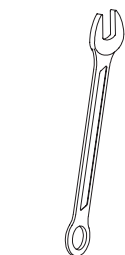
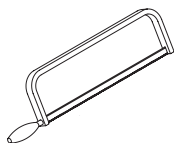
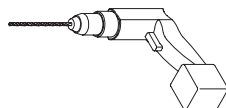

CH 18



3 mm

2 mm



ATTENZIONE!!!!

Tutte le operazioni di installazione e manutenzione richiedono l'ausilio di NR. 2 OPERATORI  
SPECIALIZZATI

WARNING!!!!

All installation and maintenance operations require 2 QUALIFIED WORKER

# ITA

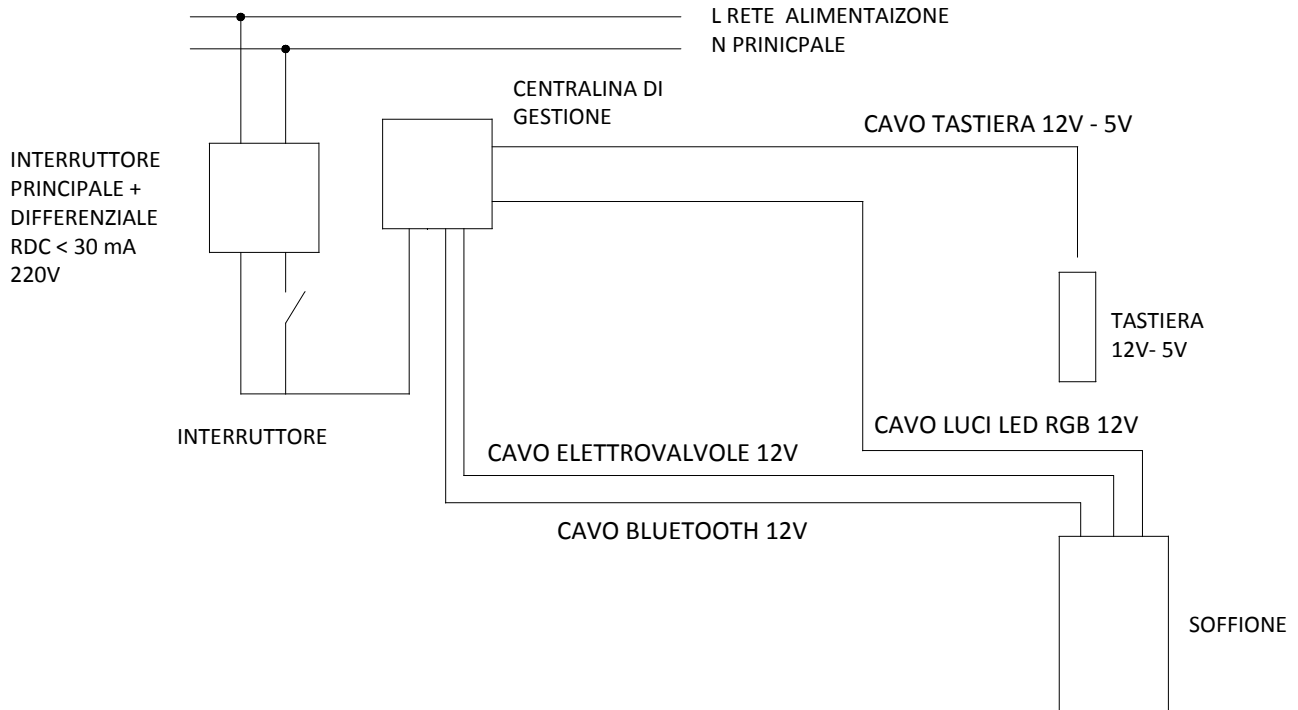

# EN-FRA

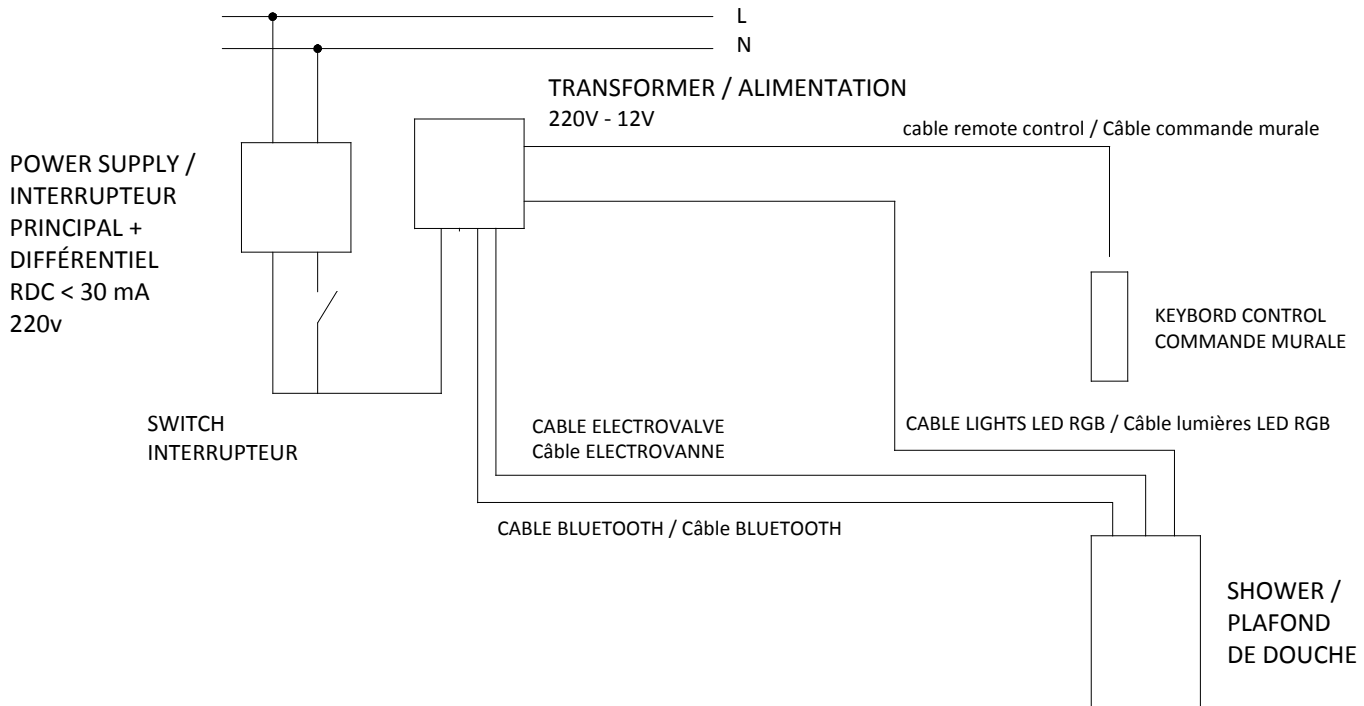

## Collegamento elettrico / Electrical connection / Branchement électrique

CAVO LED / LED CABLE / CÂBLE LED  
12 Vac (5 Mt.) ø min. 20 mm

CAVO ELETTROVALVOLE/ELECTROVALVE CABLE/CÂBLE ELECTROVANNE  
12 Vac (5 Mt.) ø min. 20 mm

CAVO BLUETOOTH/BLUETOOTH CABLE/CÂBLE BLUETOOTH  
12 Vac (5 Mt.) ø min. 20 mm

X = 780 mm.  
Y = 460 mm.  
Z = Min. 160 Max. 700 mm.

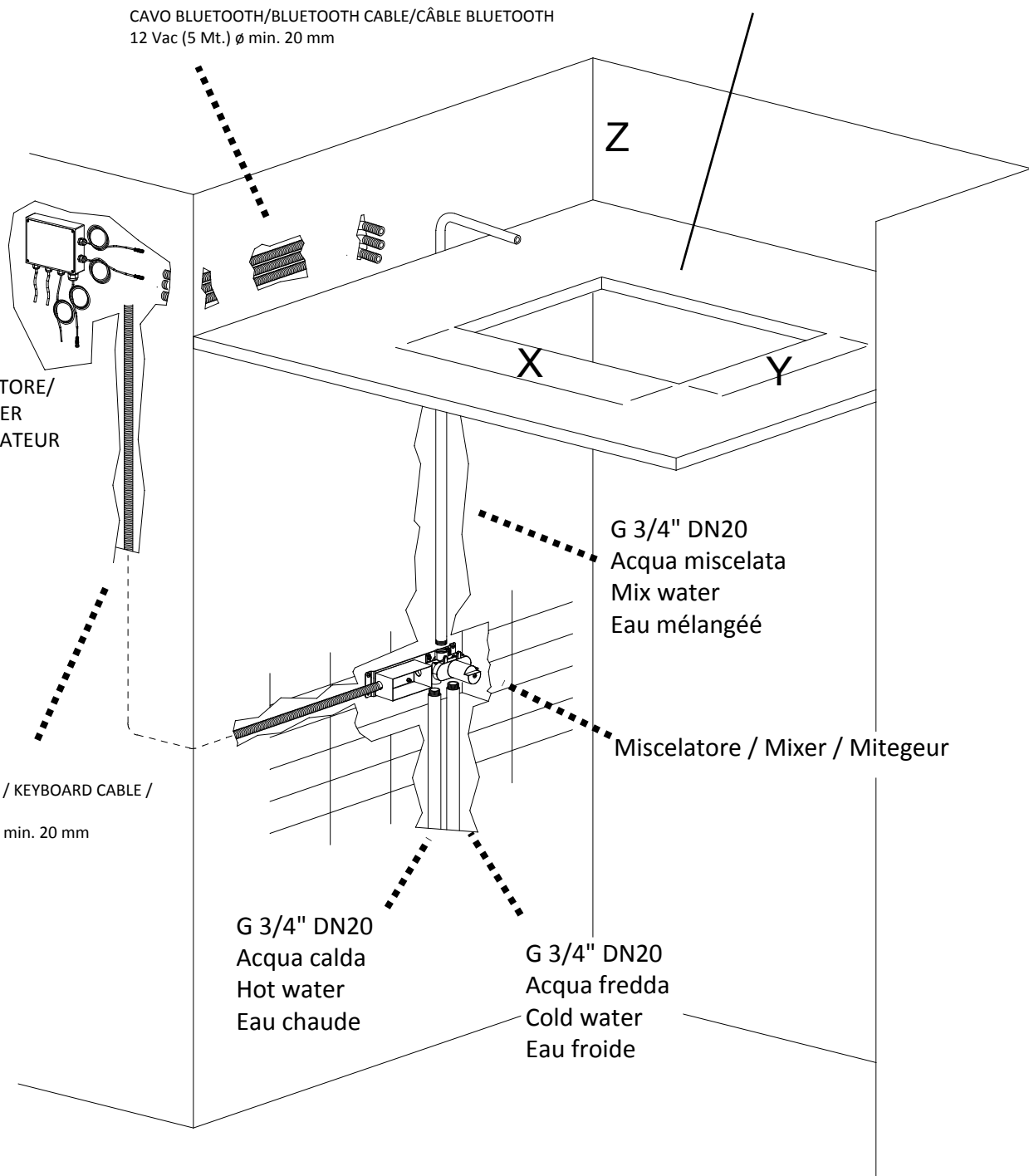

**E' necessaria l'installazione di un alimentatore ON/OFF sull'alimentazione del trasformatore**  
**Require installation of controll key for switch ON/OFF lights on trasformer power supply**  
**Il est nécessaire d'installer un interrupteur marche/arret sur l'alimentation du transformateur qui vient fourni avec produit**



a

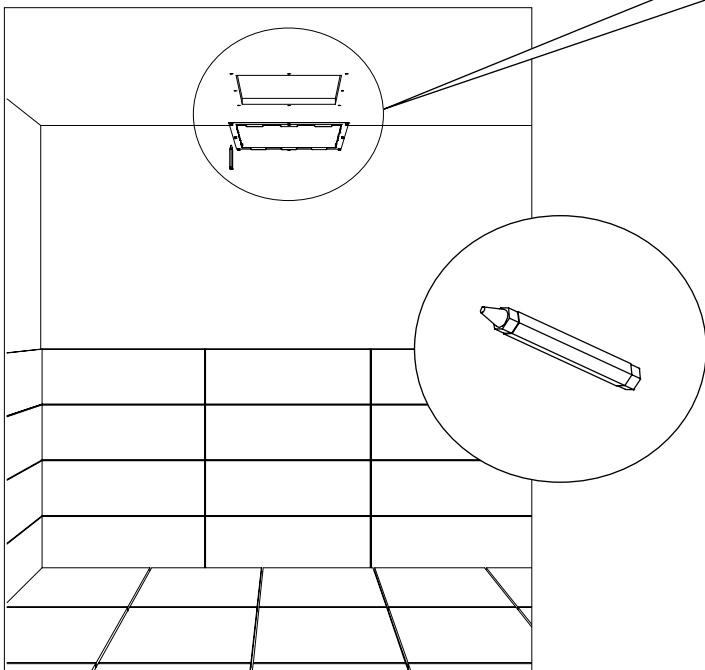
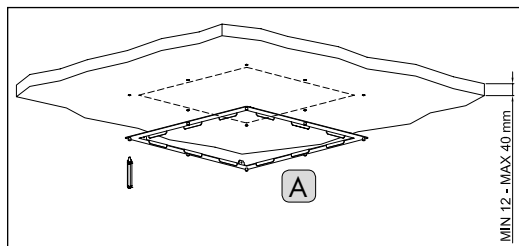

b

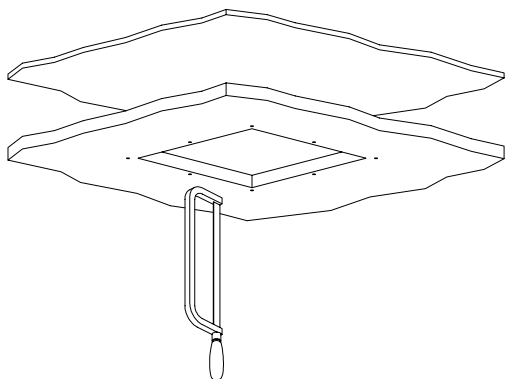

c

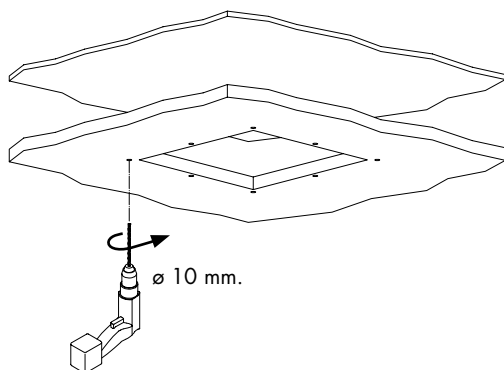

d

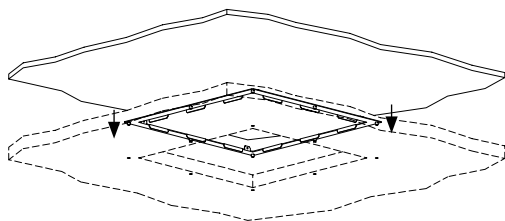

e

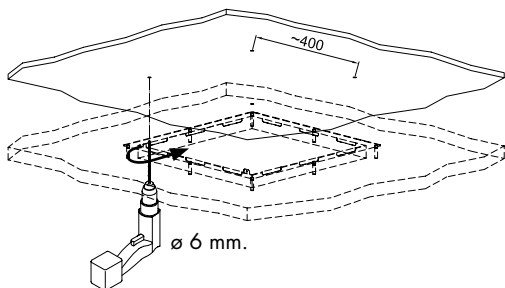

f

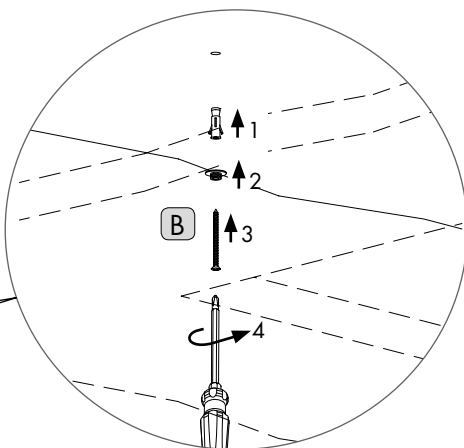
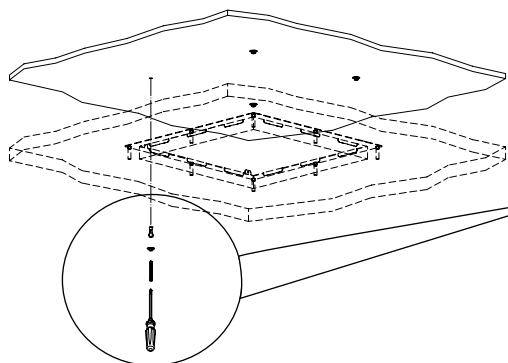

g

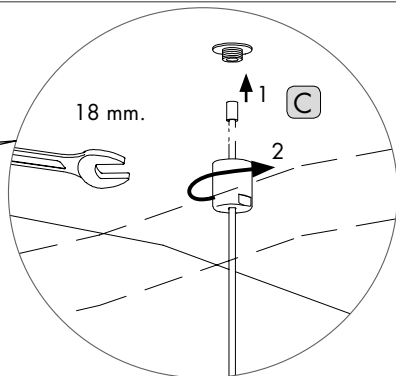
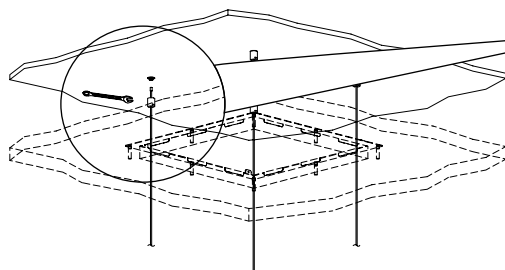

h

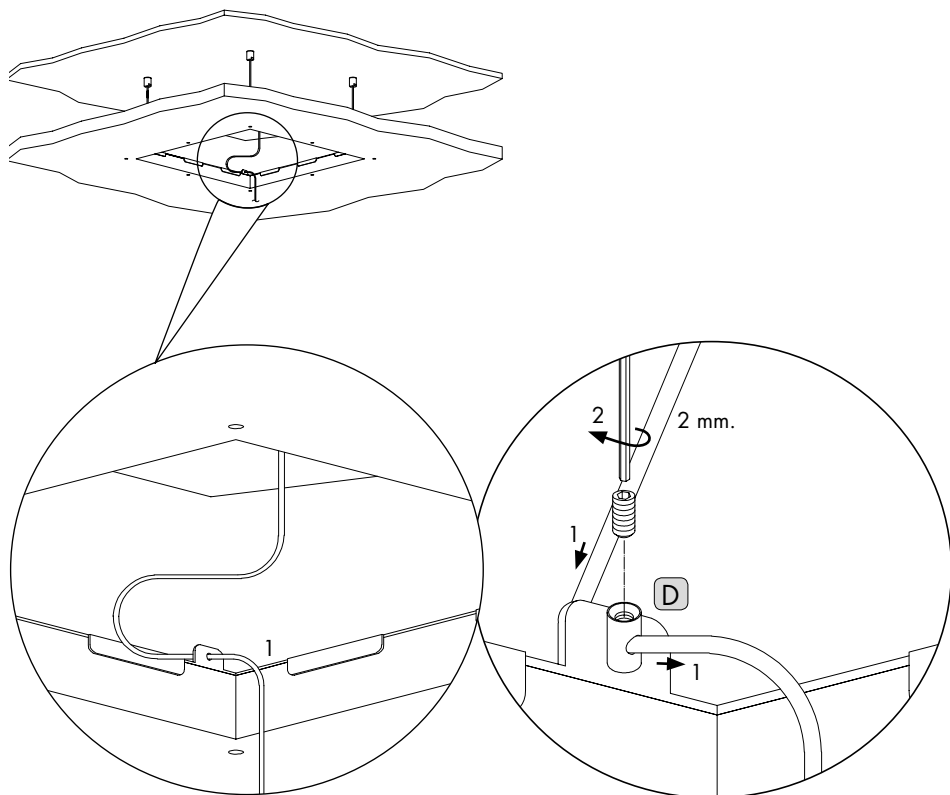

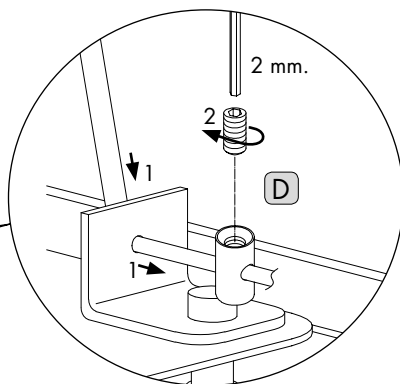
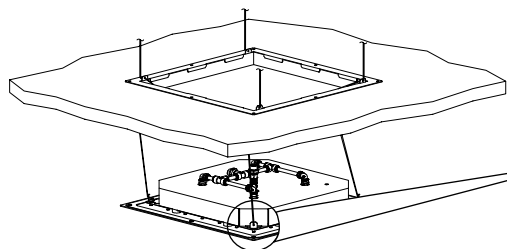
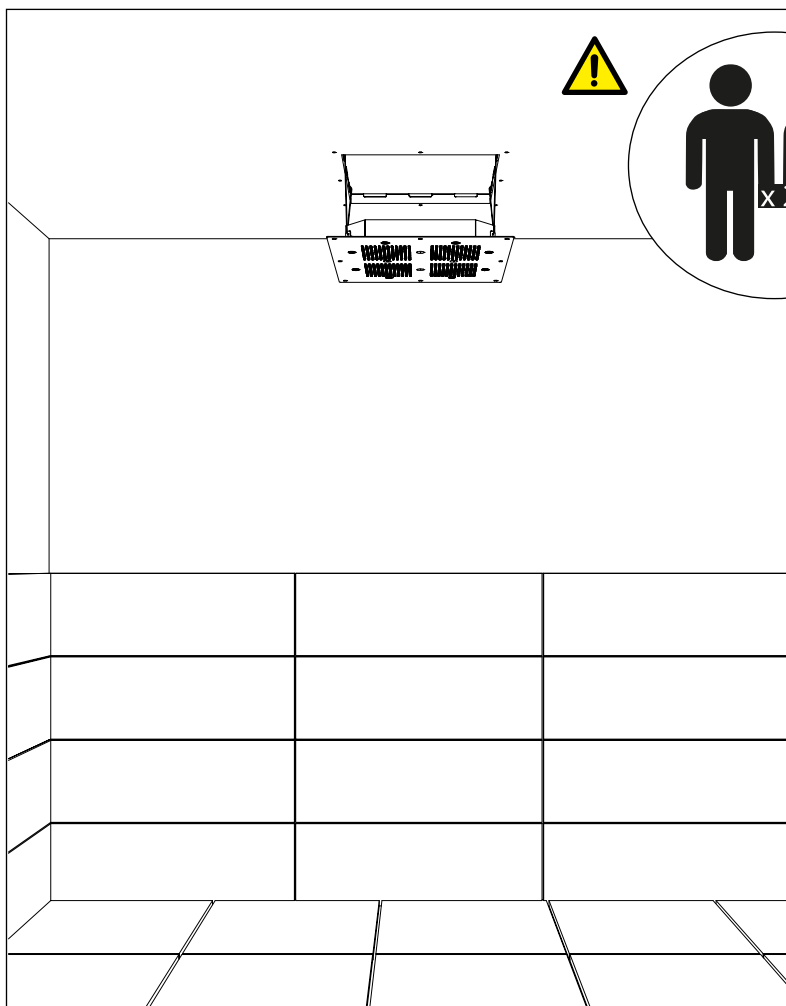

I



- Effettuare il collegamento idraulico/elettrico in base alla tipologia di soffione (Ved. pag. 9÷14)
- Make the connection to the hydraulic/electrical system according to the type showerhead. (see pag. 9÷14)
- Make the connection to the hydraulic/electrical system according to the type showerhead. (see pag. 9÷14)
- Effectuer le branchement hydraulique/électrique en fonction du type de produit (voir pages 9-14)

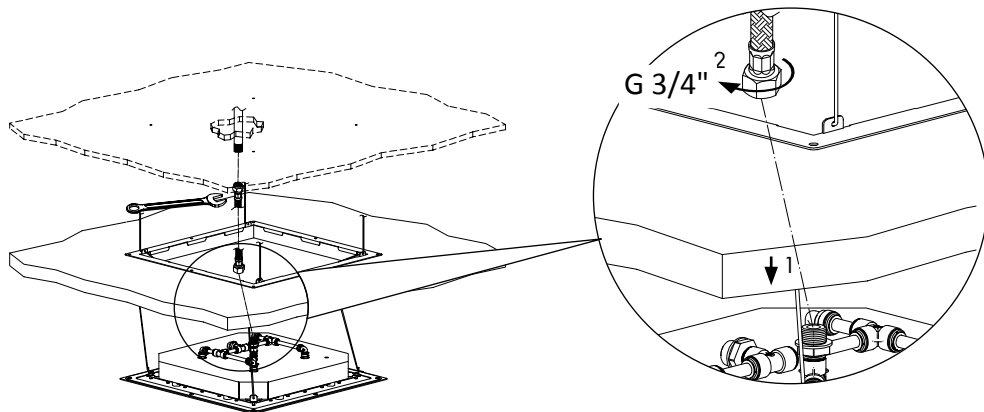

- Installare il tastierino, se previsto, seguendo le istruzioni da pag. 21, altrimenti proseguire dalla figura successiva "M"
- Install the keyboard, if applicable, following the instructions on page 21, otherwise continue with the next figure "M"
- Installer la commande murale conformément aux instructions de page 21, autrement continuer jusqu'à la figure suivante "M"

m



- Fissare il soffione al controsoffitto e serrare le viti come indicato nella figura M, prestando particolare attenzione a non rovinare la finitura.
- Install the showerhead to the false ceiling and tighten the screw as shown in the figure M, be carefully, not scratch the surface.
- Fixer le produit à faux-plafond et serrer les vis comme indiqué dans la figure "M", en accordant une attention particulière à ne pas abimer la finition.

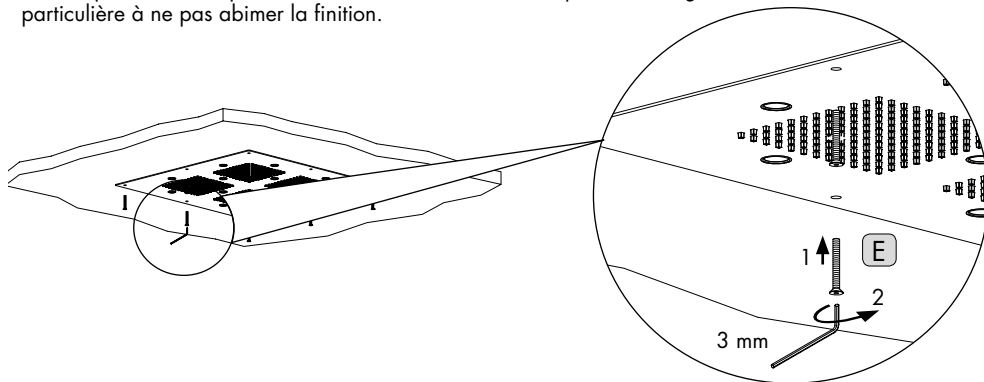



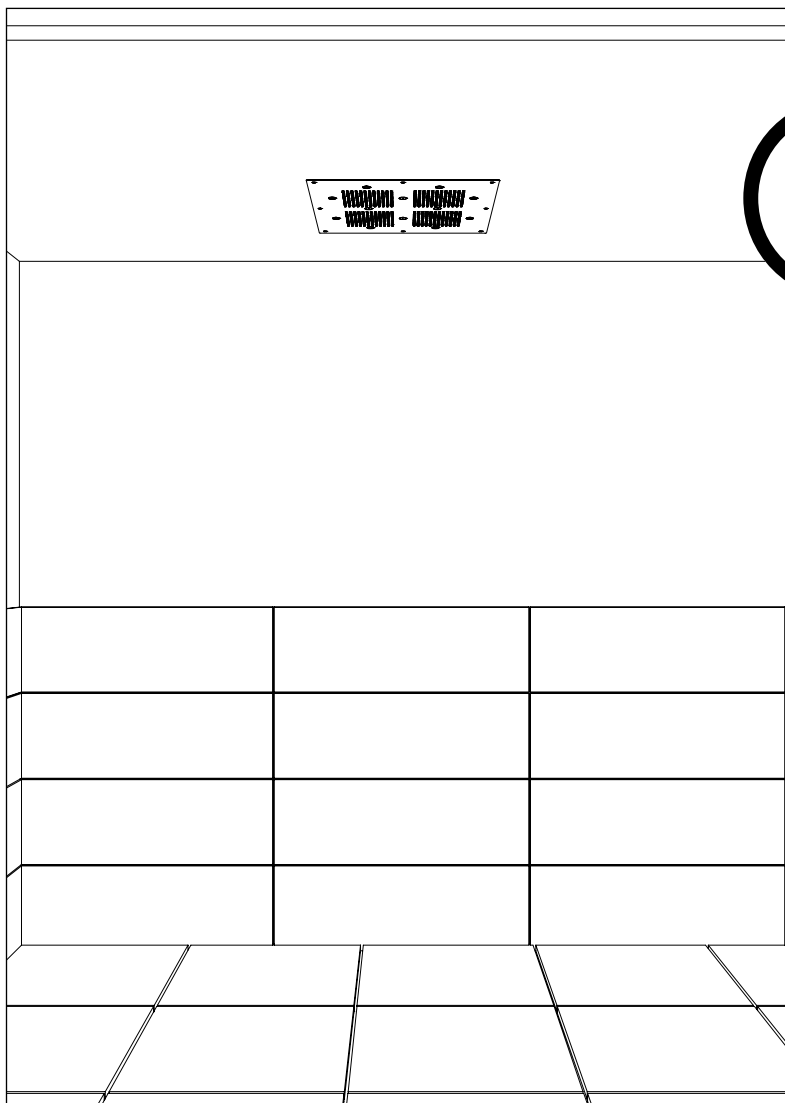



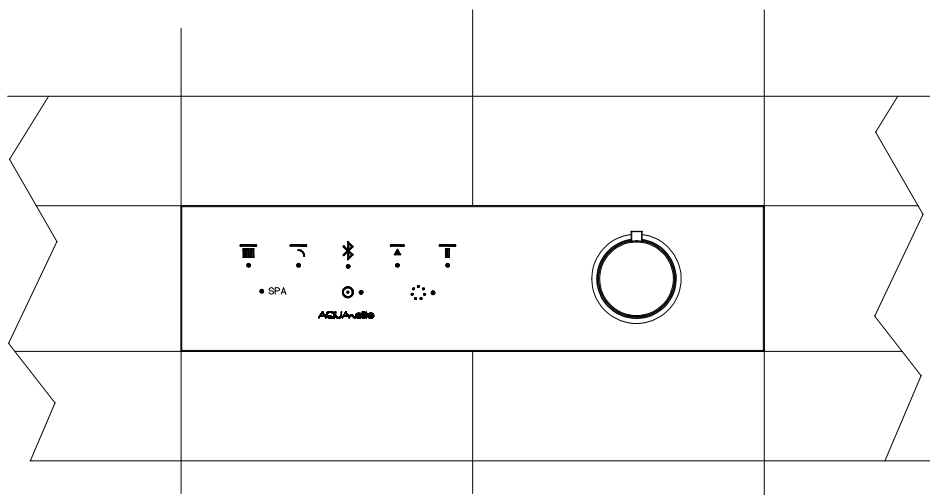

n



# Funzioni / Functions / Fonctions



-  Getto Pioggia / Rain jet / Jet pluie
-  Getto Cascata / Cascade jet / Jet cascade
-  Getto nebulizzato / Mist jet / Jet brumisation
-  Getto Colonna / Colum jet / Jet colonne d'eau
-  Bluetooth / Bluetooth / Bluetooth
-  SPA Programmi SPA / SPA program / Programmes séquentiels SPA
-  Selezioni colori e ciclo automatico / Color selections and automatic loop / Sélections couleurs et cycle automatique
-  Attivazione tastiera e off / Keyboard activation and off / Activation du clavier et arrêt

# Funzioni / Functions / Fonctions

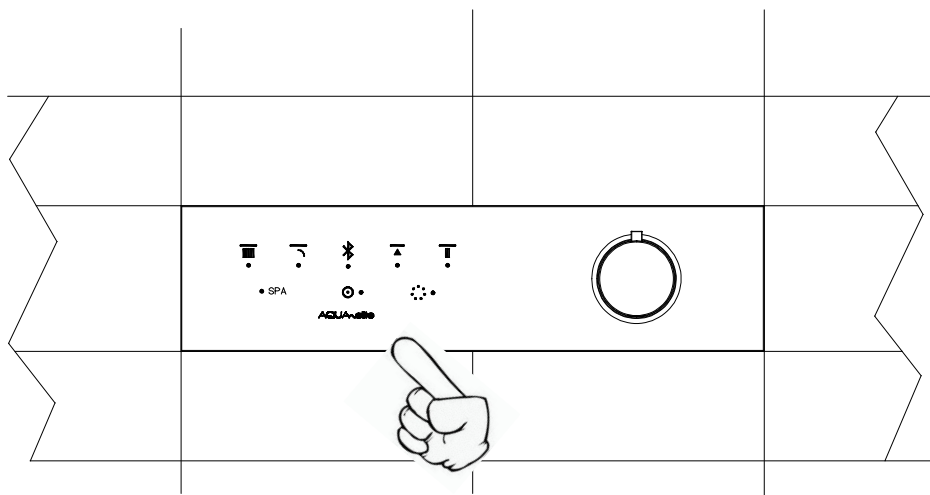

- Per attivare la tastiera tenere premuto per 3 secondi / Premere 1 volta per spegnere
- To activate the keyboard hold down for 3 seconds / Press 1 time to turn off
- Pour activer le clavier, maintenez enfoncé pendant 3 secondes / Appuyez 1 fois pour éteindre

## Programmi SPA :

n° 4 programmi differenti, in termini di tempo, getti e luci.  
Premere il led SPA per scegliere il programma.

## SPA programs :

n° 4 different programs, in term of time, jets and lights.  
Press the SPA LED to select the program.

## Programmes séquentiels SPA :

n° 4 programmes différents, en terme de temps, jgestion jet d'eau et lumières.  
Appuyer sur le symbol SPA et sélectionner le programme.

**ATTENZIONE!! : PREMERE IN CORRISPONDENZA DEL LED ACCANTO ALLA FUNZIONE CHE SI VUOLE ATTIVARE, NON SULL'ICONA**

**CAUTION!! : PRESS ON LED ON THE FUNCTION THAT WILL BE ACTIVATED, NOT ON THE ICON**

**ATTENTION !! : PRESSE SUR LA CORRESPONDANCE DE LED SUR LA FONCTION QUI SERA ACTIVÉE**



- Attivare il pulsante dedicato all'accensione del Bluetooth (1)
- Attivare il Bluetooth dal proprio dispositivo (2) ed attenderne il riconoscimento.  
Utilizzare il dispositivo per gestire la regolazione del volume e la scelta dei brani.

- Press the Bluetooth button (1)
- Activate the Bluetooth from your device (2) and wait for the identification.  
Use the device to modify the volume and songs selection.

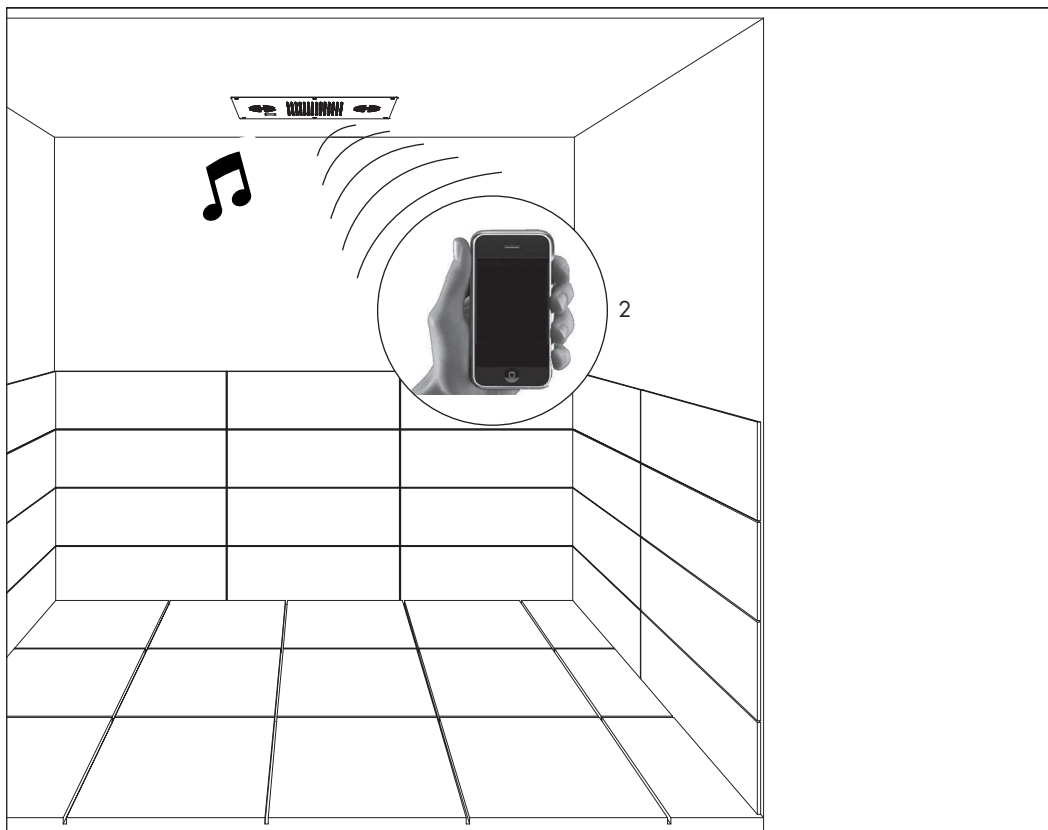

Bluetooth = SANWU Audio  
Password = Nessuna / None / Aucun

## Dichiarazione di conformità / Declaration of conformity

### CARATTERISTICHE TECNICHE

Tensione di alimentazione 220Vac +/- 3%  
Assorbimento massimo: 300 mA  
Servizio di funzionamento: Continuo  
Temperatura ambiente di funzionamento: da 0 a +40°C  
Umidità relativa senza condensa: 5% a 90%  
Grado di protezione: IP55  
Connessioni d'ingresso e d'uscita: Morsetto a carrello  
Norma di sicurezza: Non richiesta  
Norma ENIC: EN55022/B  
Prodotto LASER di Classe 2  
Le radiazioni luminose di questa classe sono considerate a basso rischio, ma potenzialmente pericolose. Normalmente non producono danni permanenti se viste per pochi istanti da un occhio non protetto.

### AVVERTENZE

Prima di collegare l'unità per la prima volta, leggere attentamente le sezioni seguenti. Le tensioni alternate delle reti elettriche variano a seconda del paese.  
Assicurarsi che la tensione alternata presente nella vostra zona sia conforme con la tensione richiesta.  
NON E' CONSENTITO L'UTILIZZO DI UNA CENTRALI DI GESTIONE DIVERSA DA QUELLA FORNITA DA ANPA.  
PRIMA DI QUALUNQUE INTERVENTO TECNICO SULLA CENTRALE DI GESTIONE DEVE ESSERE AUTORIZZATO DA UN TECNICO ANPA.  
IN CASO DI NON RISPETTO DI QUANTO SOPRA DESCRITTO LA GARANZIA NON AVRA' PIU' VALORE.

### TECHNICAL FEATURES

Voltage supply: 220Vac +/- 3%  
Maximum consumption: 300 mA  
Functioning: Continuous  
Ambient operating temperature: 0-+40 °  
Relative non-condensing humidity: 5% -90%  
Protection degree: IP55  
Input and output connection: Rising clamp terminal block  
Safety standard: Not required  
Enic standard: EN55022/b  
Class 2 LASER product  
Class 2 light radiations are considered as posing a low risk, but potentially dangerous.

### WARNING

Before connecting the unit for the first time, please read carefully the following sections.  
AC voltages varies according to each country.  
Ensure that the voltage of your local power supply corresponds to the required voltage.

### CARACTÉRISTIQUES TECHNIQUES

Tension d'alimentation : 220Vac +/- 3%  
Adsorption maximale : 300 mA  
Service de fonctionnement : continu  
Température ambiante de fonctionnement : de 0 à +40°  
Humidité relative sans condensation : de 5% à 90%  
Degrée de protection : IP55  
Connexions d'entrée et de sortie : bornes à bogies  
Normes de sécurité : non demandée  
Norme ENIC : EN55022/B  
Produit LASER Classe II  
Les radiations lumineuses de cette Classe sont considérées à bas risque, mais dangereuses potentiellement.  
Normalement ne produisent pas des dégâts permanents si vu pour quelque instant d'un oeil sans protection

### AVERTISSEMENTS

Avant de brancher l'unité la première fois, veuillez lire attentivement les sections suivantes.  
Les voltages des réseaux électriques varient à second du pays.  
S'assurer que le voltage dans votre zone soit conforme avec le voltage prévu et déclaré par l'usine.

## Dichiarazione di conformità / Declaration of conformity / Déclaration de conformité

### CARATTERISTICHE TECNICHE

Tensione di alimentazione 12Vcc +/- 3%  
Assorbimento massimo: 1.3 A – 8.4 A  
Servizio di funzionamento: Continuo  
Temperatura ambiente di funzionamento: da 0 a +40°C  
Umidità relativa senza condensa: 5% a 90%  
Grado di protezione: IP55  
Conessioni d'ingresso e d'uscita: Morsetto a carrello  
Norma di sicurezza: Non richiesta  
Norma ENIC: EN55022/B  
Prodotto LASER di Classe 2  
Le radiazioni luminose di questa classe sono considerate a basso rischio, ma potenzialmente pericolose. Normalmente non producono danni permanenti se viste per pochi istanti da un occhio non protetto.

### AVVERTENZE

Prima di collegare l'unità per la prima volta, leggere attentamente le sezioni seguenti. I voltaggi CA delle reti elettriche variano a seconda del paese. Assicurarsi che il voltaggio presente nella vostra zona sia conforme con il voltaggio richiesto.

### ALIMENTATORE

Tensione di alimentazione: ingresso 190 -230 VAC 50/60Hz +/- 20% uscita - 12Vcc +/- 3%  
Potenza: 48 Watt  
Si consiglia vivamente di utilizzare l'alimentatore fornito da Anpa; In caso di utilizzo di alimentatore diverso assicurarsi che le caratteristiche richieste siano compatibili con l'apparecchio.  
L'utilizzo di alimentatori con caratteristiche diverse o incompatibili possono danneggiare irreparabilmente il prodotto e far decadere la garanzia.

### TECHNICAL FEATURES

Voltage supply: 12 Vcc +/- 3%  
Maximum consumption: 1.3 A – 8.4 A  
Functioning: Continuous  
Ambient operating temperature: 0- +40 °  
Relative non-condensing humidity: 5% -90%  
Protection degree: IP55  
Input and output connection: Rising clamp terminal block  
Safety standard: Not required  
Enic standard: EN55022/b  
Class 2 LASER product  
Class 2 light radiations are considered as posing a low risk, but potentially dangerous.

### WARNING

Before connecting the unit for the first time, please read carefully the following sections.  
AC voltages varies according to each country.  
Ensure that the voltage of your local power supply corresponds to the required voltage.

### FEEDER

Voltage supply: Input 190 -230 VAC 50/60Hz +/- 20% output - 12Vcc +/- 3%  
Power: 48 Watt  
It is strongly recommended to use the feeder provided by anpa.  
If a different feeder is to be used, please ensure that is compatible with the device.  
The use of feeders with different characteristics or incompatible may damage the product and invalidate the warranty.

### CARACTÉRISTIQUES TECHNIQUES

Tension d'alimentation : 12Vcc +/- 3%  
Adsorption maximale : 1.3 A - 8.4 A  
Service de fonctionnement : continu  
Température ambiante de fonctionnement : de 0 à +40°  
Humidité relative sans condensation : de 5% à 90%  
Degrée de protection : IP55  
Connexions d'entrée et de sortie : bornes à bogies  
Normes de sécurité : non demandée  
Norme ENIC : EN55022/B  
Produit LASER Classe II  
Les radiations lumineuses de cette Classe sont considérées à bas risque, mais dangereuses potentiellement.  
Normalement ne produisent pas des dégâts permanents si vu pour quelque instant d'un oeil sans protection

### AVERTISSEMENTS

Avant de brancher l'unité la première fois, veuillez lire attentivement les sections suivantes.  
Les voltages des réseaux électriques varient à second du pays.  
S'assurer que le voltage dans votre zone soit conforme avec le voltage prévu et déclaré par l'usine.

### ALIMENTATEUR

Tension d'alimentation : entrée 190 - 230 VAC 50/60Hz +/- 20% sortie - 12Vcc +/- 3%  
Puissance : 48W  
Il est fortement recommandé d'utiliser l'alimentateur fourni avec le produit.  
En cas d'utilise d'un alimentateur différent, s'assurer que les caractéristiques demandées soient compatibles avec l'appareil.  
L'utilise d'alimentateurs avec caractéristiques différentes ou incompatibles puissent endommager le produit irrémédiablement et faire invalider la garantie.

**CARATTERISTICHE TECNICHE**

Tensione di alimentazione 12Vcc +/- 3%  
 Assorbimento massimo: 1.3 A – 8.4 A  
 Servizio di funzionamento: Continuo  
 Temperatura ambiente di funzionamento: da 0 a +40°C  
 Umidità relativa senza condensa: 5% a 90%  
 Grado di protezione: IP55  
 Connessioni d'ingresso e d'uscita: Morsetto a carrello  
 Norma di sicurezza: Non richiesta  
 Norma ENIC: EN55022/B

**Prodotto LASER di Classe 2**

Le radiazioni luminose di questa classe sono considerate a basso rischio, ma potenzialmente pericolose. Normalmente non producono danni permanenti se viste per pochi istanti da un occhio non protetto.

**AVVERTENZE**

Prima di collegare l'unità per la prima volta, leggere attentamente le sezioni seguenti. I voltaggi CA delle reti elettriche variano a seconda del paese.  
 Assicurarsi che il voltaggio presente nella vostra zona sia conforme con il voltaggio richiesto.

**ALIMENTATORE**

Tensione di alimentazione:  
 ingresso 190 -230 VAC 50/60Hz +/- 20%  
 uscita - 12Vcc +/- 3%  
 Potenza: 48 Watt

Si consiglia vivamente di utilizzare l'alimentatore fornito da Anpa; In caso di utilizzo di alimentatore diverso assicurarsi che le caratteristiche richieste siano compatibili con l'apparecchio. L'utilizzo di alimentatori con caratteristiche diverse o incompatibili possono danneggiare irreparabilmente il prodotto e far decadere la garanzia.

**TECHNICAL FEATURES**

Voltage supply: 12 Vcc +/- 3%  
 Maximum consumption: 1.3 A – 8.4 A  
 Functioning: Continuous  
 Ambient operating temperature: 0- +40 °  
 Relative non-condensing humidity: 5% -90%  
 Protection degree: IP55  
 Input and output connection: Rising clamp terminal block  
 Safety standard: Not required  
 Enic standard: EN55022/B

**Class 2 LASER product**

Class 2 light radiations are considered as posing a low risk, but potentially dangerous.

**WARNING**

Before connecting the unit for the first time, please read carefully the following sections.  
 AC voltages varies according to each country.  
 Ensure that the voltage of your local power supply corresponds to the required voltage.

**FEEDER**

Voltage supply:  
 Input 190 -230 VAC 50/60Hz +/- 20%  
 output - 12Vcc +/- 3%  
 Power: 48 Watt

It is strongly recommended to use the feeder provided by anpa. If a different feeder is to be used, please ensure that is compatible with the device.  
 The use of feeders with different characteristics or incompatible may damage the product and invalidate the warranty.

DICHIARAZIONE DI CONFORMITÀ



Noi,

**ANPA srl**

Viale dello Sport 16/18 - 21026 Gavirate (VA) Italy

Dichiariamo che il prodotto descritto in questo manuale è conforme alla Direttiva 2006/95/CE relativa al "Materiale elettrico destinato ad essere adoperato entro taluni limiti di tensione" e alla Direttiva 2004/108/CE relativa alla "Compatibilità Elettromagnetica"

DECLARATION OF CONFORMITY



We,

**ANPA srl**

Viale dello Sport 16/18 - 21026 Gavirate (VA) Italy

declare that the product featured in these instructions conforms to Directive 2006/95/CE relating to "Electrical equipment designed for use within certain voltage limits" and to Directive 2004/108/CE relating to "Electromagnetic compatibility".

**CARACTÉRISTIQUES TECHNIQUES**

Tension d'alimentation : 12Vcc +/- 3%  
Adsorption maximale : 1.3 A - 8.4 A  
Service de fonctionnement : continu  
Température ambiante de fonctionnement : de 0 à +40°  
Humidité relative sans condensation : de 5% à 90%  
Degrée de protection : IP55  
Connexions d'entrée et de sortie : bornes à bogies  
Normes de sécurité : non demandée  
Norme ENIC : EN55022/B

**Produit LASER Classe II**

Les radiations lumineuses de cette Classe sont considérées à bas risque, mais dangereuses potentiellement.  
Normalement ne produisent pas des dégâts permanents si vu pour quelque instant d'un œil sans protection.

**AVERTISSEMENTS**

Avant de brancher l'unité la première fois, veuillez lire attentivement les sections suivantes.

Les voltages des réseaux électriques varient à second du pays.  
S'assurer que le voltage dans votre zone soit conforme avec le voltage prévu et déclaré par l'usine.

**ALIMENTATEUR**

Tension d'alimentation :  
entrée 190 - 230 VAC 50/60Hz +/- 20%  
sortie - 12Vcc +/- 3%  
Puissance : 48W

Il est fortement recommandé d'utiliser l'alimentateur fourni avec le produit.

En cas d'utilise d'un alimentateur différent, s'assurer que les caractéristiques demandées soient compatibles avec l'appareil.  
L'utilise d'alimentateurs avec caractéristiques différentes ou incompatibles puissent endommager le produit irrémédiablement et faire invalider la garantie.

DÉCLARATION DE CONFORMITÉ



Nous,

**ANPA srl**

Viale dello Sport 16/18 - 21026 Gavirate (VA) Italy

Déclarons que le produit décrit dans cette guide est conforme à la Directive 2006/95/CE relative au "Matériel électrique destiné à être employé dans certains limites de tension" et à la Directive 2004/108/CE relative à la "Compatibilité Électromagnétique".

**Dati tecnici generali per l'impianto idraulico**

Pressione minima di esercizio: 1.5 bar  
 Pressione di esercizio: campo di impiego ottimale consigliato 2.5 - 4 bar  
 Pressione massima di esercizio: 5 bar  
 (Per pressioni idrauliche superiori si consiglia l'utilizzo di un riduttore di pressione)  
 Temperatura massima di esercizio: 65 C°  
**I soffioni a parete sono dotati di limitatore di portata 12 lt/min. (ove possibile).**

**Funzionamento minimo dei soffioni ad incasso:**

Getto a pioggia: 16 lt/min. - 1.5 bar  
 Cascata singola: 10 lt/min. - 2 bar  
 Doppia cascata: 14 lt/min. - 2 bar

**Funzionamento ottimale dei soffioni ad incasso:**

Getto a pioggia: 18 lt/min. - 2.5 bar  
 Cascata singola: 14 lt/min. - 2.5 bar  
 Doppia cascata: 17 lt/min. - 2.5 bar

**PROTEZIONE AMBIENTALE**

I dispositivi elettrici ed elettronici non devono essere considerati rifiuti domestici. I consumatori sono obbligati dalla legge a restituire i dispositivi elettrici ed elettronici alla fine della loro vita utile ai punti di raccolta collettivi preposti per questo scopo o nei punti vendita.

**Technical information for the hydraulic system**

Minimum operating pressure: 1,5 bar  
 Operating Pressure: Optimal recommended use 2.5- 4 bar  
 Maximum operating pressure: 5 bar  
 (for higher hydraulic pressure it is recommended a pressure reducer)  
 Maximum operating temperature: 65 C°  
**Wall mount shower heads are equipped with a 12 l/m flow rate reducer (where possible).**

**Minimum supply required for false ceiling shower heads:**

Rain function: 16 l/m - 1.5 bar  
 Cascade function: 10 l/m - 2 bar  
 Double cascade function: 14 l/m - 2 bar

**Optimal supply for false ceiling shower heads:**

Rain function: 18 l/m - 2.5 bar  
 Cascade function: 14 l/m - 2.5 bar  
 Double cascade function: 17 l/m - 2.5 bar

**ENVIRONMENTAL PROTECTION**

Electrical and electronic equipment is not to be treated as domestic refuse.  
 Consumers are obliged by law to dispose of no-longer useful electrical and electronic equipment at the appropriate collection or sales points.

**Données techniques générales pour installation hydraulique**

Pression minimale d'exercice: 1.5 bar  
 Pression d'exercice optimale: 2.5 - 4 bar  
 Pression maximale d'exercice: 5 bar  
 (pour pressions hydrauliques supérieures, l'utilisation d'un réducteur de pression est fortement recommandée)  
 Température maximale d'exercice : 65 C°  
**Les pommes de douche à mur sont équipées d'un limiteur de débit d'eau à 12 lt/min. (ou possible).**

**Fonctionnement minimal des plafonds de douche à encastrer à faux-plafond:**

Jet pluie: 16 lt/min. - 1.5 bar  
 Jet cascade single: 10 lt/min. - 2 bar  
 Jet cascade double: 14 lt/min. - 2 bar

**Fonctionnement optimale des plafonds de douche à encastrer à faux-plafond:**

Jet pluie: 18 lt/min. - 2.5 bar  
 Jet cascade single: 14 lt/min. - 2.5 bar  
 Jet cascade double: 17 lt/min. - 2.5 bar

**ENVIRONNEMENT**

Les dispositifs électriques et électroniques NE doivent PAS être considérés comme des déchets domestiques.  
 Les consommateurs sont obligés par la loi à retourner les dispositifs électriques et électroniques, à la fin de leur vie utile, aux points de collecte collectifs faits pour ça ou aux points de vente.

AQUA<sup>h</sup>elite

Aquaelite | Anpa Srl

Viale dello Sport, 16/18, 21026 Gavirate - VA - Italy

T.+39 0332 732906 | F. +39 0332 735819 | [www.aquaelite.it](http://www.aquaelite.it) | [info@aquaelite.it](mailto:info@aquaelite.it)